

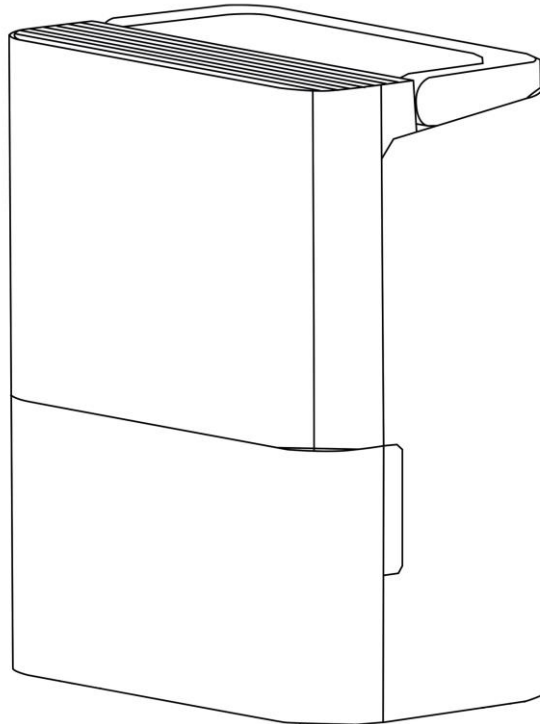

Russell Hobbs

10L Dehumidifier



Model Number: RHDH1001

220-240V AC 50Hz 340W

For Customer Services & Spare Parts please call **0345 209 7461**

Or visit us at <https://mda.russellhobbs.com>

PLEASE RETAIN
FOR FUTURE REFERENCE

CONTENTS

	Page(s)
Safety Instructions and Electrical Safety	3 - 4
Feature Diagram	5
Control Panel Diagram	6
Positioning your Dehumidifier	7
Using your Dehumidifier	8 – 13
Emptying your Dehumidifier	13 – 14
Cleaning and Care	15 – 16
Troubleshooting	17
Guarantee and Customer Services	18
Spare Parts	19
Connection to the Mains Supply	20
Specification	21
Notes	22 – 23

Safety Instructions

Important note: Please read this booklet before installing and switching on this appliance. The manufacturer assumes no responsibility for incorrect installation and usage as described in this booklet.

- This model uses natural refrigerant gas as part of its cooling system. This gas is known as R290 (Propane) and is environmentally friendly but can be combustible. Care should therefore be taken when handling or transporting the product to ensure that none of the refrigeration circuit components are damaged,
- Do not obstruct ventilation openings in the appliance.
- Do not cover the appliance or place any object on the control panel
- The appliance must not be placed or rested on its power cord.
- Do not use adaptors or extension leads when connecting the appliance to the electrical power supply
- Do not plug in if the plug is damaged.
- Do not pull, twist or damage the power cable.
- Do not plug-in or un-plug the appliance with wet hands to prevent electrical shock.
- Always store the unit in an upright position in order to maintain the compressor working in a proper condition.
- Never insert your finger or any other object into the air outlet
- This appliance can be used by children aged from 8 years and above and persons with reduced physical, sensory or mental capabilities or lack of experience and knowledge if they have been given supervision or instruction concerning use of the appliance in a safe way and understand the hazards involved. Children should not play with the appliance.
- This appliance is designed to be used by adults, do not allow children to play with the appliance.
- The appliance is intended for residential use only.

Safety Instructions

- Do not use in the following locations:-
 - Next to a source of fire.
 - An area where oil is likely to splash.
 - An area exposed to direct sunlight.
 - An area where water is likely to splash.
 - Near a bath, shower or a swimming pool.
 - In a greenhouse.
 - An area where flammable gasses or liquids are present.



Caution: Risk of fire/
flammable materials

(Required for R32/R290 units only)



IMPORTANT NOTE: Read this manual carefully before installing or operating your new air conditioning unit. Make sure to save this manual for future reference.

Electrical Safety

THIS APPLIANCE MUST BE PLUGGED INTO AN EARTHED SOCKET

- Before switching on, make sure that the voltage of your electricity supply is the same as that indicated on the rating plate. This product is designed to operate on 220 – 240V AC; 50Hz. Connection to any other power source may damage the unit.
- This product may be fitted with a non re-wireable plug. If it is necessary to change the fuse in the plug, the fuse cover must be refitted. If the fuse cover becomes lost or damaged, the plug must not be used until a suitable replacement is obtained.
- If the plug has to be changed because it is not suitable for your socket, or becomes damaged in any way, it should be cut off and an appropriate plug fitted. This should be carried out by a qualified electrician. The plug removed must be disposed of safely, as insertion into a 13 Amp socket is likely to cause an electrical hazard.

FEATURE DIAGRAM

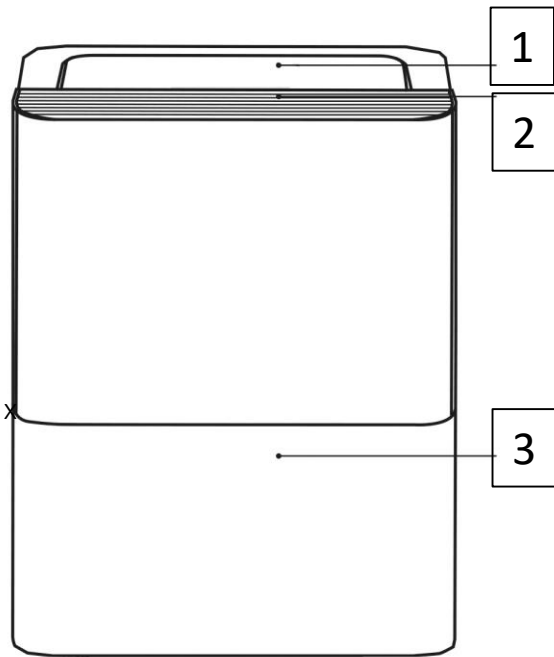

Front

1. Control panel
2. Air outlet grille
3. Water tank

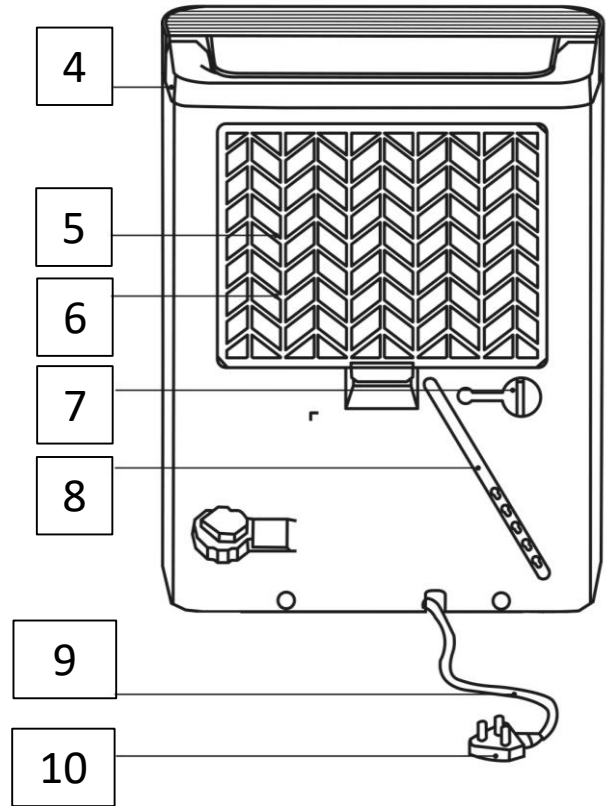

Rear

4. Handle
5. Air intake grille
6. Air filter (behind the air intake grille)
7. Drain hose outlet
8. Power cord storage band
9. Power cord
10. Plug

For Customer Services & Spare Parts please call **0345 209 7461**
Or visit us at <https://mda.russellhobbs.com>

CONTROL PANEL DIAGRAM

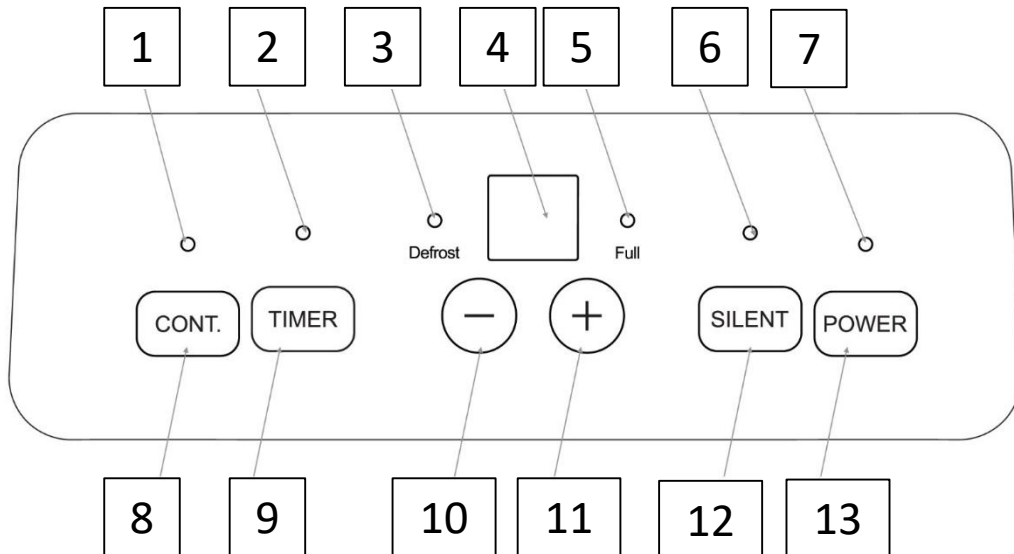

1. Continuous dehumidifier mode indicator
2. Timer indicator
3. Defrost indicator
4. LED display
5. Water tank full indicator
6. Silent mode indicator
7. Power indicator
8. Continuous dehumidifier mode button
9. Timer button
10. Up control button
11. Down control button
12. Silent mode button
13. Power button

POSITIONING YOUR DEHUMIDIFIER

- This dehumidifier is intended for indoor residential applications only. This dehumidifier should not be used for commercial or industrial applications.
- Place the dehumidifier on a smooth, level floor strong enough to support the unit with a full drawer of water.
- Allow at least 20cm of air space on all sides of the unit for good air circulation.
- Allow at least 40cm of air space above the unit for good air circulation.

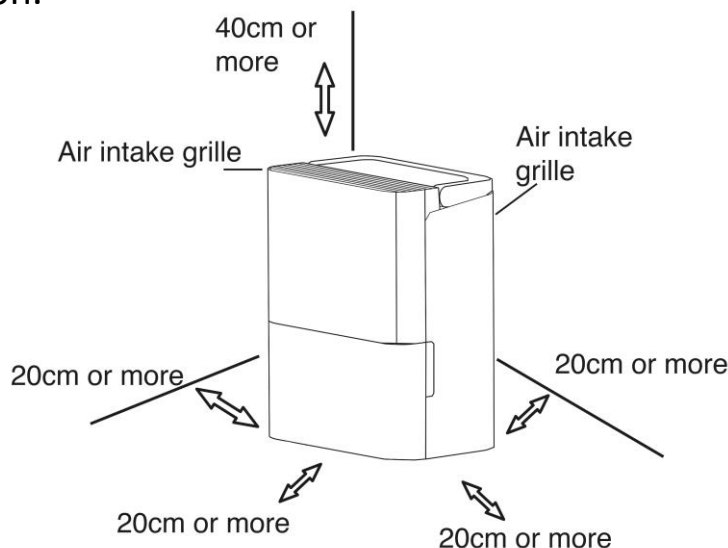

- Place the unit in an area where the temperature will not fall below 5°C (41 ° F). The coils can become covered with frost at temperatures below 5°C (41 ° F), which may reduce performance.
- Place the unit away from clothes dryers, heaters or radiators.
- The dehumidifier must be operated in an enclosed area to be most effective.
- Close all doors, windows and other outside openings
- Do not use outdoors.

USING YOUR DEHUMIDIFIER

When using the dehumidifier for the first time, run the unit in continuous mode for 24 hours

When the water tank is full the unit will automatically shut off or when the tank is removed. The fan motor may continue for a period of 30 seconds after shut off, this is normal

After the unit has stopped, the unit cannot be restarted for 3 minutes. This is a safety feature to protect the appliance. If the unit is not turned off then unit will automatically start after 3 minutes.

The unit has frost protection, this means that when frost builds up inside the unit the compressor will turn off and the fan will continue to run to remove the frost. Once the frost is removed the compressor will operate again.

If power to the unit is broken unexpectedly (power cut), once power is restored the unit will restart on the function it was running prior to the power being broken.

Turning the Unit On

- Remove all packaging and plug the unit into a socket.
- Ensure the water tank is correctly positioned, the drain plug is in place in the back of the unit if you are using the tank to collect the water.
- Press the Power button to turn the dehumidifier on and off. The power indicator light will illuminate when the unit is turned on.
- When the unit is first switched on, the display shows the actual room % humidity level (within 5% accuracy).
- The humidity level can be set using the instructions for “Setting the Humidity”.

USING YOUR DEHUMIDIFIER

Continuous Dehumidifier (Extraction) Mode

- For maximum extraction rate, the Continuous Dehumidifier (Extraction) mode should be used.
- Press the Continuous Dehumidifier (Extraction) button on the control panel. The Continuous Dehumidifier indicator light will illuminate when this mode is selected.
- The unit will continue to run at the maximum extraction rate until the water tank reaches the max fill level.
- Press the Continuous Extraction button again to cancel the continuous extraction.

Note: The humidity cannot be set when the unit is operating in Continuous Dehumidifier (Extraction) Mode

Setting the Humidity

- The desired humidity level can be set within a range of 35% to 85% Relative Humidity in 5% increments / decrements by pressing the + and – keys.
- To select the desired humidity level ensure the unit is not on the continuous mode. This can be done by checking the CONT. indicator is not illuminated. If it is then simply press the CONT button to de-activate the continuous mode and the CONT. indicator will switch off.
- Use the Up and Down control buttons to select the desired humidity. The display will flash while the humidity is being set.
- For drier air, press the pad and set to a lower percent value(%).
- For damper air, press the pad and set a higher percent value(%).

Note: The humidity cannot be set when the unit is operating in Continuous Dehumidifier (Extraction) Mode

USING YOUR DEHUMIDIFIER

Setting the Timer

Delayed Start

- The unit must be switched OFF for the Auto Start function to be programmed.
- With the unit switched off, press the Timer button until the Timer indicator light is illuminated. “0.0” will be displayed on the LED display.
- Use the up and down control buttons to select the desired delayed start time.
- The delayed start time can be adjusted in 0.5 hour increments up to 10 hours, and then in 1 hour increments up to 24 hours.
- The selected time will stay on the display for 5 seconds, and will then disappear. The countdown to the start time can be viewed by pressing the Timer button again.

Auto Stop

- The Auto Stop function can only be set when the unit is ON.
- Press the Timer button until the Timer Off indicator is illuminated.
- Use the up and down controls to select the desired end time.
- The stop time can be adjusted in 0.5 hour increments up to 10 hours, and then in 1 hour increments up to 24 hours.
- The selected time will stay on the display for 5 seconds, and will then disappear. The Auto Stop time can be viewed by pressing the Timer button again.

- Both the Delayed Start and Auto Stop functions can be initiated in the same sequence. In this instance, both Timer On and Off indicators will be illuminated.

Note: Turning the unit On or Off at any time will cancel the Delayed Start or Auto Stop functions and the unit can take 2 minutes to restart.

If the time is adjusted to “0.0” this will also cancel the Timer function.

If the water drawer is full or “P2” is displayed, the Delayed Start and Auto Stop functions will be cancelled.

USING YOUR DEHUMIDIFIER

Silent Mode

- To reduce the noise output, for example, when being used at night, the silent mode can be activated. In this mode, the fan speed is slower and the unit will be running at a lower extraction rate.
- Press the Silent button. When the silent mode is selected the light will display green.
- Press the Silent button again to cancel the Silent mode. The unit will return to the standard fan speed.
- The humidity level can be set when the unit is running in Silent mode using the instructions for “Setting the Humidity”, however the fan speed and extraction rate will be lower.

USING YOUR DEHUMIDIFIER

Other features

Auto Shut Off

The dehumidifier will shut off automatically under the following conditions:

- When the water tank is full
- When the water tank is removed
- When the water tank is not replaced in the proper position
- When the selected humidity level is reached

Water Drawer Full Indicator light

- The indicator light will illuminate under the following conditions:
- When the water tank is full
- When the water tank is removed
- When the water tank is not replaced in the proper position

3 Minute Restart

After the unit has stopped, it cannot be restarted for 3 minutes. This is to protect the unit. Operation will automatically start after 3 minutes.

Auto Defrost

When frost builds up on the evaporator coils, the compressor will cycle off and the fan will continue to run until the frost disappears.

When this function is enabled, the Defrost light will illuminate.

Auto-Restart

If the unit turns off unexpectedly due to a power cut, it will restart with the previous function setting automatically when the power resumes.

USING YOUR DEHUMIDIFIER

Error Codes

P2 – Water drawer is full or drawer is not in the right position. Empty the drawer and replace in the correct position.

AS - Humidity module sensor error. Unplug the unit and plug it back in. If error repeats, call customer service.

ES - Tube Temperature sensor error. Unplug the unit and plug it back in. If error repeats, call customer service.

EC -Refrigerant leakage detection. With this new technology, the display area will appear EC when the unit detects refrigerant leakage, call customer service

EMPTYING YOUR DEHUMIDIFIER

There are two ways to remove collected water:

Collection in the Water Tank

- When the water tank is full, the unit will automatically stop running, and the Full indicator light will illuminate.
- Slowly pull out the tank and grip the left and right handles securely and carefully. Pull out the water tank straight so the water in the tank does not spill. Do not put the tank down because the bottom of the drawer is uneven.
- Empty the water and replace the tank. The tank must be correctly inserted for the dehumidifier to restart operation.
- The machine will restart operation after 3 minutes

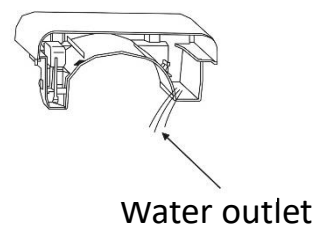
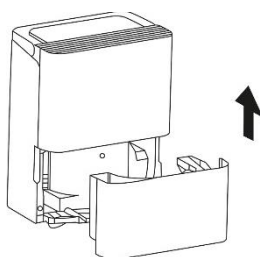
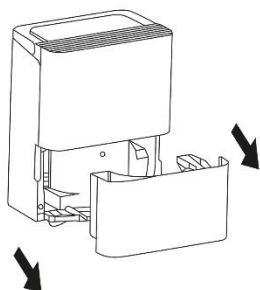

EMPTYING YOUR DEHUMIDIFIER

- When you remove the water tank, do not touch any parts inside of the unit. Doing so may damage the product.
- Be sure to push the water tank gently all the way into the unit. Banging the tank against anything or failing to push it in securely may cause the unit not to operate.
- When you remove the water tank, if there is some water in the unit you must dry it .

Continuous Draining

- Water can be automatically emptied into a floor drain by attaching the unit with a inner diameter 13.5mm hose .
- Remove the rubber bung from the Drain Hose Outlet on the back of the unit.
- Attach the hose into the Drain Hose Outlet in the back of the unit as shown below.

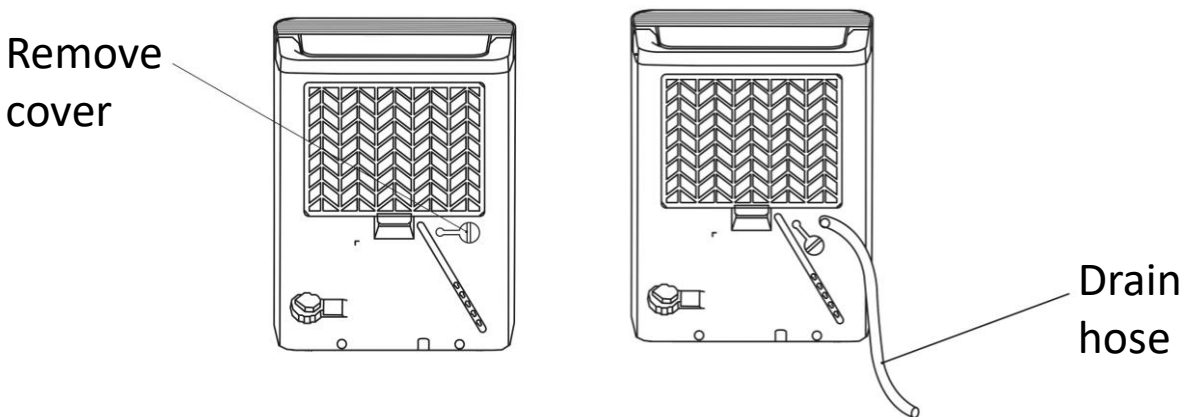

- Lead the water hose to a suitable drainage facility. The drainage facility should be lower than the drain outlet of the unit.
- Be sure to run the water hose sloping downward and let the water to flow out smoothly.
- NOTE: When the continuous drain feature is not being used, remove the drain hose from the outlet and attach the rubber plug back to the drain outlet.

CLEANING AND CARE

Cleaning the Air Filter

The air filter is located behind the air intake grill on the rear of the appliance and should be checked and cleaned at least every 30 days or more often if necessary.

NOTE: DO NOT PUT THE FILTER IN AN AUTOMATIC DISHWASHER

To Remove the Air Filter:

- Grip the tab on the filter and pull the filter upwards and then out
- Clean the filter with warm, soapy water. Rinse and let the filter dry before replacing it. Do not clean the filter in a dishwasher.

To Replace the Air Filter

- Insert the filter into the unit, then push the filter upward.
- When re-install the filter, please press the middle buckles of the filter first and then pat the bottom buckle

CAUTION:

DO NOT operate the dehumidifier without a filter. This will cause dirt and lint to build up and clog the unit and will reduce performance.

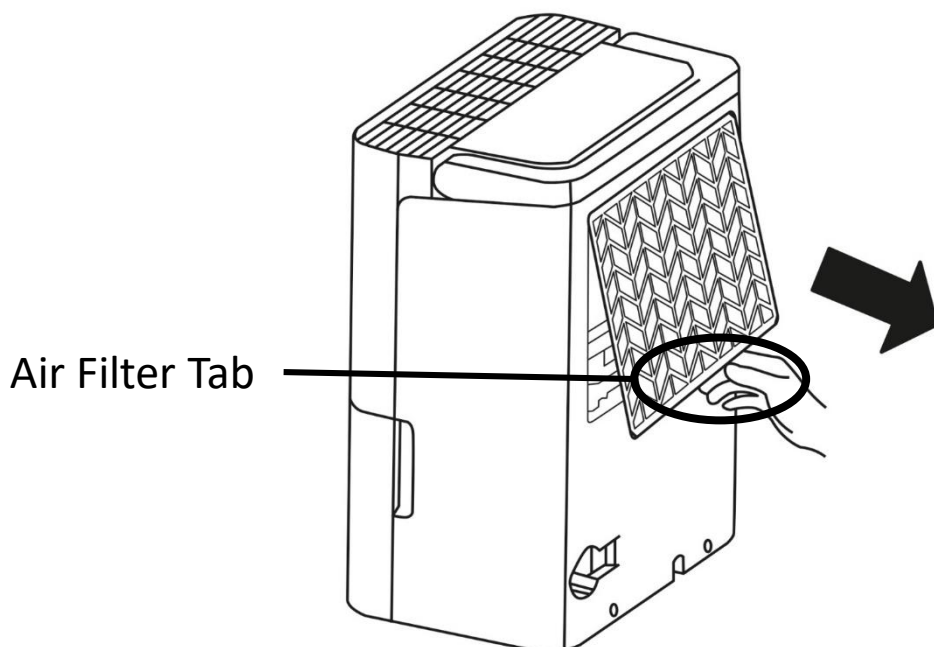

CLEANING AND CARE

Turn the dehumidifier off and remove the plug from the wall outlet before cleaning.

Cleaning the Grille and Case

- Use water and a mild detergent. Do not use bleach or abrasives.
- Do not splash water directly onto the main unit. Doing so may cause an electrical shock, cause the insulation to deteriorate, or cause the unit to rust.
- The air intake and outlet grilles get soiled easily, so use a vacuum attachment or brush to clean.

Cleaning the Water Tank

- Every few weeks, clean the tank to prevent growth of mould, mildew and bacteria. Partially fill the tank with clean water and add a little mild detergent. Swish it around in the tank, empty and rinse.

NOTE: Do not use a dishwasher to clean the tank. After clean, the tank must be in place and securely seated for the dehumidifier to operate.

When not using the unit for long time periods

- After turning off the unit, wait 24 hours before emptying the drawer.
- Clean the main unit, drawer and air filter.
- Wrap the cord and bundle it with the band and cover the unit with a plastic bag.
- Store the unit upright in a dry, well-ventilated place.

TROUBLE SHOOTING

Problem	What to check
Unit does not start	<ul style="list-style-type: none"> • Make sure the dehumidifier's plug is pushed completely into the socket outlet. • Check the house fuse/circuit breaker box. • Dehumidifier has reached its preset level or drawer is full. • Drawer is not in the proper position. • If the unit is being restarted there is a 3 min delay before the unit will start running. • Ensure the unit is not set on delayed start function. • Ensure the room humidity is not lower than 35%.
Dehumidifier does not dry the air as it should	<ul style="list-style-type: none"> • Did not allow enough time to remove the moisture. • Make sure there are no curtains, blinds or furniture blocking the front or back of the dehumidifier. • The humidity selector may not be set low enough. • Check that all doors, windows and other openings are securely closed. • Room temperature is too low, below 5° C(41° F). • There is a kerosene heater or something giving off water vapour in the room.
The unit makes a loud sound when operating	<ul style="list-style-type: none"> • The air filter is clogged. • The unit is tilted instead of upright as it should be. • The floor surface is not level.
Frost appears on the coils	<ul style="list-style-type: none"> • This is normal. The unit has Auto defrost feature.
Water on the floor	<ul style="list-style-type: none"> • Hose to connector or hose connection may be loose. • Intend to use the drawer to collect water, but the back drain plug is removed.
Power indicator light flashes 5 times per second	<ul style="list-style-type: none"> • Temperature sensor or humidity sensor error. Unplug the unit and plug it back in.

GUARANTEE AND CUSTOMER SERVICES

At Russell Hobbs, we take all our customer feedback seriously.

Feel free to contact our Customer Service Team, on 0345 209 7461 who will be more than happy to assist you.

This product is guaranteed for **12 months** from the date of the original purchase. If any defect arises due to faulty materials or workmanship, the faulty product must be returned to the place of purchase.

Refund or replacement is at the discretion of the retailer.

The following conditions apply:

- The product must be returned to the retailer with the original proof of purchase.
- The product must be installed and used in accordance with the instructions contained in this instruction guide and any other instructions for use which are supplied.
- It must be used for domestic purposes only and for its intended use.
- This warranty does not cover wear and tear, damage, misuse or consumable parts.

This does not affect your statutory rights.

For Customer Services & Spare Parts please call **0345 209 7461**

Or visit us at <https://mda.russellhobbs.com>

SPARE PARTS

To check the availability of the following spare parts, simply contact our friendly Customer Services team using the details provided at the bottom of this page.

Air Filter

Drain Hose Bung

For Customer Services & Spare Parts please call **0345 209 7461**
Or visit us at **<https://mda.russellhobbs.com>**

CONNECTION TO THE MAINS SUPPLY

This appliance is designed to operate from a mains supply of
220-240V~ 50Hz.

Check that the voltage marked on the product corresponds
with your supply voltage.

How to change the fuse

1. Slot the end of a screwdriver into the recess in the fuse holder of the plug.
2. Pull the fuse holder upwards until free of the plug and slide the fuse out.
3. Insert the new fuse by sliding into the fuse holder and refit the fuse holder by pushing this onto the plug until locked into place.

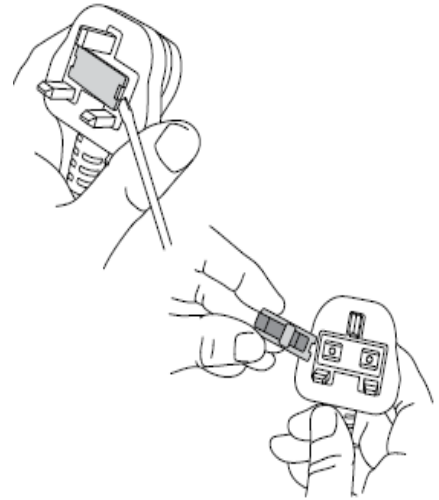

Important: Only ever use a 13 amp fuse.

Specification

Model	RHDH1001
Voltage	220 – 240V 50Hz
Power Input	340W
Moisture Removal	10L per day (DB = 30°C RH = 80%)
Refrigerant	R290/45g
Overall Size (D x W x H)	21cm x 32cm x 40cm
Operating Temperature	5°C - 35°C
Weight	11.4Kg

Notes

Notes



Russell Hobbs

For Customer Services & Spare
Parts please call
0345 209 7461
Or visit us at
<https://mda.russellhobbs.com/>

Revision 2
Model: RHDH1001

Made by G2S Ltd
under license.
G2S Limited, Wigan,
WN2 4AY



This symbol is known as the 'Crossed-out wheellie bin Symbol'. When this symbol is marked on a product/batteries, it means that the product/batteries should not be disposed of with your general household waste. Only discard electrical/electronic/battery items in separate collection schemes, which cater for the recovery and recycling of materials contained within. Your co-operation is vital to ensure the success of these schemes and for the protection of the environment. For your nearest disposal facility, visit www.recycle-more.co.uk or ask in store for details.

We reserve the right, due to possible changes to design, to alter the instruction manual without prior notice.