

# PORTABLE AIR COOLER

Model: HACLP-MD43WH



- Humidifying function
  - 3 speeds
  - Oscillation

**HEINER**

## 1. INTRODUCTION

Please read the instructions carefully and keep the manual for future information.

This manual is designed to give all necessary instructions concerning installation, use and maintenance of the unit. In order to operate the unit correctly and safely, please read this instruction manual carefully before installation and use.

## 2. CONTENT OF YOUR PACKAGE

- ➔ **Portable air cooler**
- ➔ **User manual**
- ➔ **Certificate of warranty**
- ➔ **Declaration of conformity**

## 3. SAFETY INSTRUCTIONS

### GENERAL

**Read all instructions carefully and keep this manual for future reference.**

1. This appliance can be used by children aged from 8 years and above and persons with reduced physical, sensory, or mental capabilities or lack of experience and knowledge if they have been given supervision or instruction concerning use of the appliance in a safe way and understand the hazards involved. Children shall not play with the appliance. Cleaning and user maintenance shall not be done by children without supervision.
2. Children of less than 3 years should be kept away unless continuously supervised. Children aged from 3 years and less than 8 years shall only switch on/off the appliance if it has been placed or installed in its intended normal operating position and they have been given supervision or instruction concerning use of the appliance in a safe way and understand the hazards involved.
3. Never insert fingers, pencils, or any other object through the grille when the air cooler is running.
4. Disconnect the air cooler from power when moving from one location to another.
5. Be sure the air cooler is on a stable surface when operating to avoid overturning.
6. Check the voltage indicated on the rating label. This product is designed for 100-240V~50/60Hz electric supply.
7. After the water tank is filled with water, do not tilt or collide with the unit when placing or moving it. To move the unit body, please drive it slowly from the side to prevent water overflow.
8. If the supply cord is damaged, it must be replaced by the manufacturer or its service agent or a similarly qualified person to avoid a hazard.
9. To protect against the risk of electrical shock, do not immerse the unit, cord, or plug in water or other liquid.
10. Do not bend, clamp, or damage the power cord and the power plug.
11. When the appliance is not in use and before cleaning, unplug it from the outlet.
12. The water in the tank may easily deteriorate and generate odor if the room temperature is too high.
13. If the room temperature is lower, this is best to use warm water for humidification.
14. Do not place the unit directly above the power outlet.
15. Be aware that high humidity levels may encourage the growth of biological organisms in the environment.
16. Do not allow absorbent materials, such as carpeting, curtains, drapes, or tablecloths, to become damp.
17. Unplug the appliance during filling and cleaning. Never leave water in the reservoir when the appliance is not in use.
18. Empty and clean the appliance before storage & clean the appliance before next use.

19. When the unit is running, do not knock at or shock the unit body forcibly or it may lead to automatic shutdown, in which case simply restart the unit.
20. It is intended for indoor and household use only.

## 4. PRODUCT DESCRIPTION

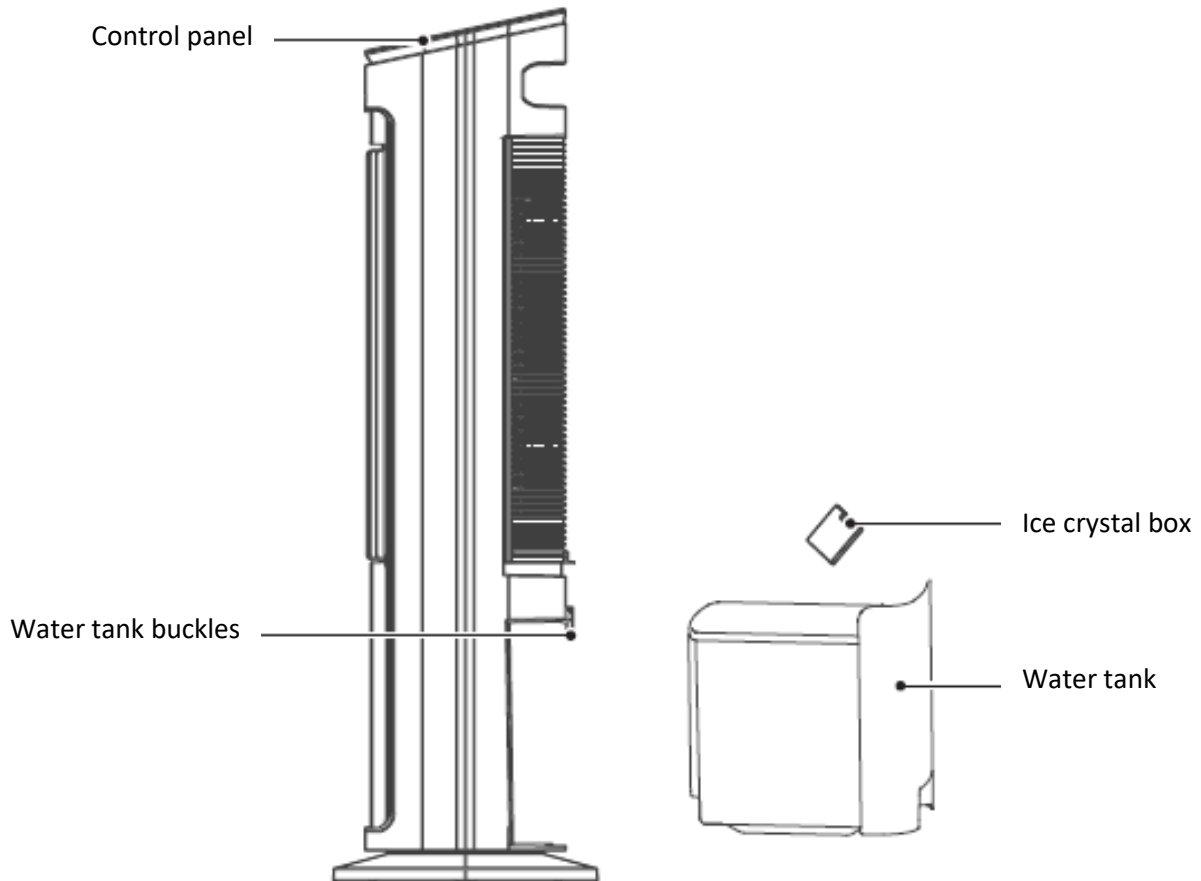

## 5. USING THE APPLIANCE

### BASE INSTALLATION

1. Take the two parts of the base out of the box, align the centers of the two bases and place them crosswise, then rotate one of the bases to align the holes and snap them together.





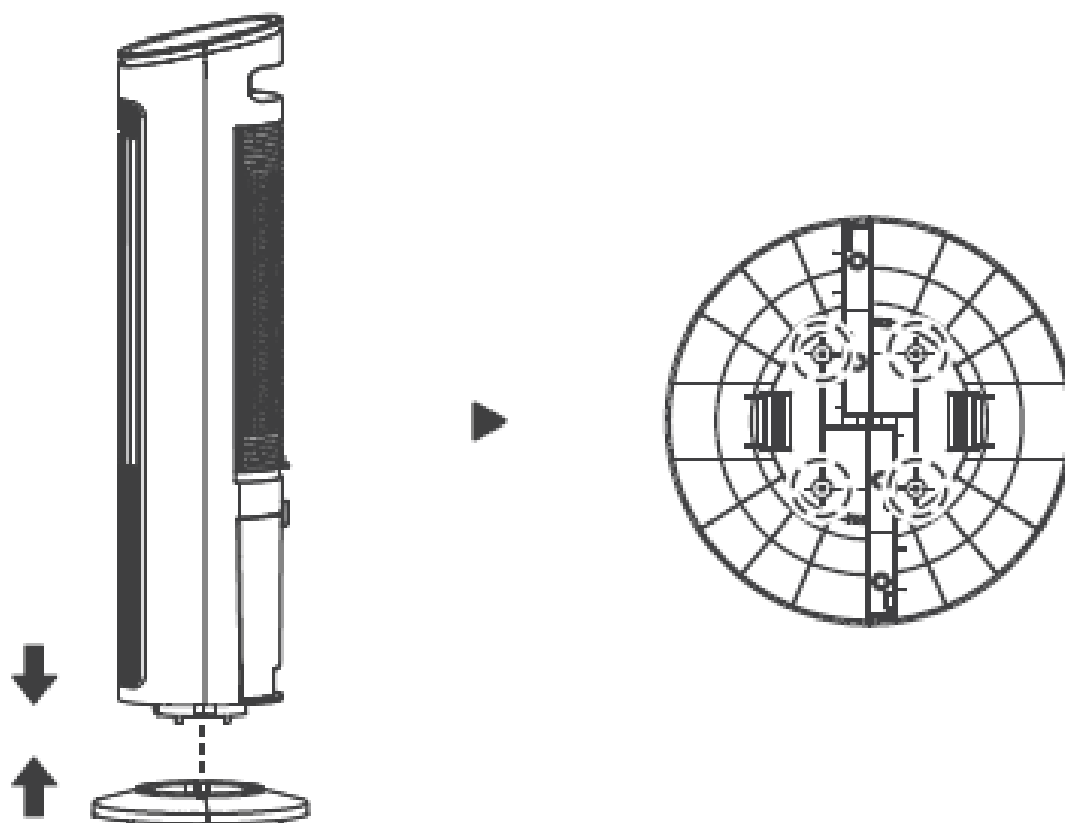









2. Align the fuselage clip line with the base clip line, and press the fuselage into the base, you can fix it with screws at the mark of the base.



## CONTROL PANEL





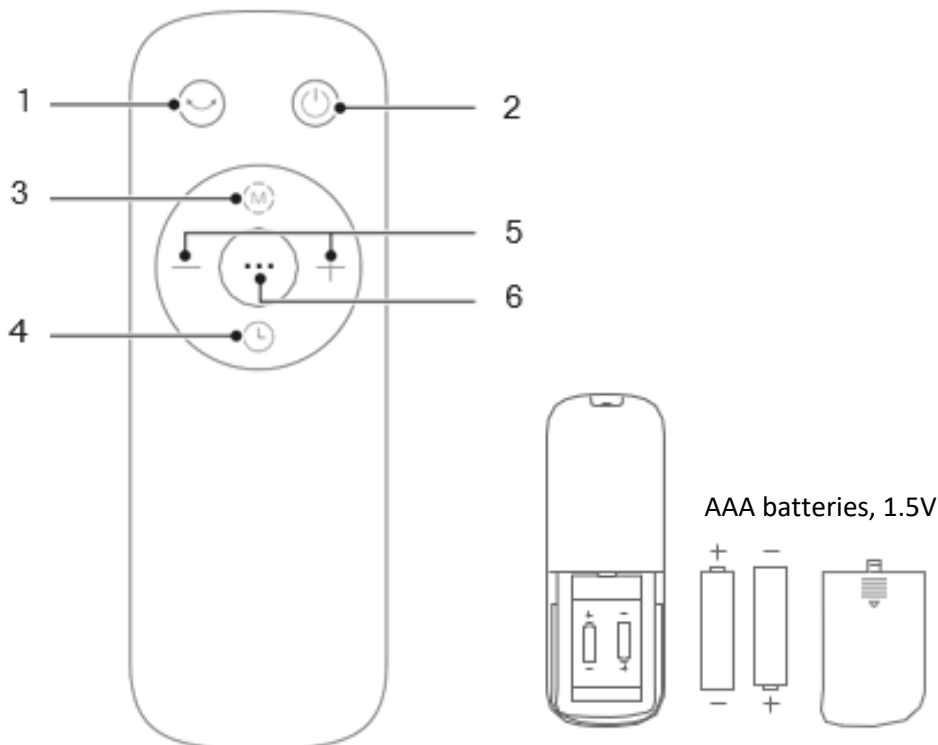

Button	Function description
	<ul style="list-style-type: none"> <li>Product starts or stops.</li> <li>The anion indicator light  is on when the product is on, and the light is off when the product is turned off .</li> </ul>
 OSC	<ul style="list-style-type: none"> <li>Touch this button to start/stop the swing.</li> </ul>
 SPEED	<ul style="list-style-type: none"> <li>Short press this button to switch wind speed, low  , medium  , high  .</li> </ul>
 MODE	<ul style="list-style-type: none"> <li>Short press this key to choose from three wind types: Normal wind (3 gears, wind speed indicator light on), Sleep wind (2 gears, sleep wind  indicator light on),</li> <li>Baby wind (1 gear, baby wind  indicator light on).</li> </ul>
 TIMER	<ul style="list-style-type: none"> <li>In the startup state, press this key, the indicator light will be on, and briefly press this key to set the timed shutdown time.</li> <li>In standby mode, press this key, the indicator light will be on , and briefly press this key to set the reserved startup time.</li> </ul>
 COOLER	<ul style="list-style-type: none"> <li>Press briefly in the power on state to turn on or turn off the cool air. In dry or hot weather, turn on the cool wind function for better experience.</li> <li>If the  indicator light flashes, please add water in time and briefly press again to turn on this function.</li> </ul>

## REMOTE CONTROL

- The remote control should be normally used within 5 meters of the front of the product.
- Both machine body operation " " and remote control " ... " are buttons for activating the cooled wind.



	Button	Function description
1		Open/stop air swing
2		Startup/Standby
3		Set wind mode
4		Set the timed shutdown/reserved startup
5	- +	“+” indicates accelerating wind speed “-” indicates decreasing wind speed
6		Open/close cool wind

### Batteries installation

1. Slide the battery compartment cover.



Fig 1

2. Insert the batteries and make sure that they are placed as shown in figure 2.

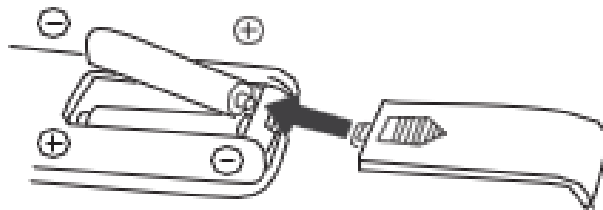

Fig 2

3. Slide back the battery cover.



Fig 3

#### Note:

- Use “AAA” size manganese or alkaline batteries. Do not use rechargeable batteries.
- Do not dispose of batteries in fire, batteries may explode or leak.
- Do not mix old and new batteries.
- Do not mix alkaline, standard (carbon-zinc) or rechargeable (nickel-cadmium) batteries.
- Non-rechargeable batteries are not to be recharged.
- Batteries are to be inserted with the correct polarity.
- The batteries must be removed from the remote controller before it is scrapped; they need to be disposed of safely.

## WATER TANK & ICE BOX INSTALATION & USAGE

1. Pull out the water tank completely and place it on a stable place.

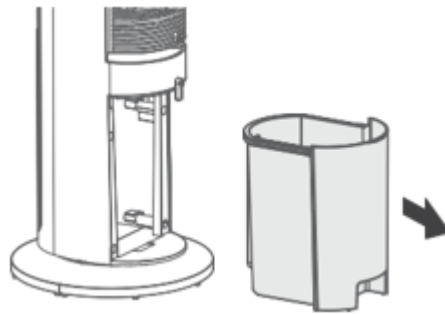

2. Add water and the ice box and push the water tank back into the appliance.

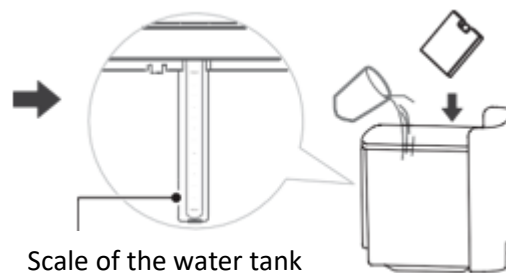

### Note:

- The ice crystal box can be frozen repeatedly and recycled; You can also choose not to use it based on the temperature.
- Please keep the ice crystal box closed to prevent from damage and liquid leakage.
- The ice crystal box is made of eco-friendly and toxic-free materials and can be refrigerated in fridge safely.
- Ice blocks can be used to replace the frozen ice crystal box, to exert the same cooling effect.
- Control the water level of the water tank to be lower than the "max" (maximum) indicating scale when feeding water, and if the water level is lower than "min" (minimum) indicating scale, please feed water in time.

## 6. CLEANING AND MAINTENANCE

The air cooler requires minimal maintenance. Do not try to fix it by yourself. Refer to a qualified service personnel if technical maintenance is needed.

1. Before cleaning and assembling, unplug the fan power.
2. To ensure adequate air circulation to the motor, keep vents at the rear of the motor free of dust. Do not disassemble the air cooler to remove dust.
3. Please wipe the exterior parts with a soft cloth soaked in a mild detergent.
4. Do not use any abrasive detergent or solvents to avoid scratching the surface.
5. Do not use any of the following as a cleaner: gasoline, thinner.
6. Do not allow water or any other liquid entering into the motor housing or interior parts.
7. Plastic parts should be cleaned with a soft cloth moisten with mild soap thoroughly remove soapsuds with dry cloth.

## WATER TANK'S CLEANING & REFILLING

1. Push the water tank button out to the horizontal state.



2. Pull out the water tank completely, place it on a stable place, add water and push the water tank into the fuselage.

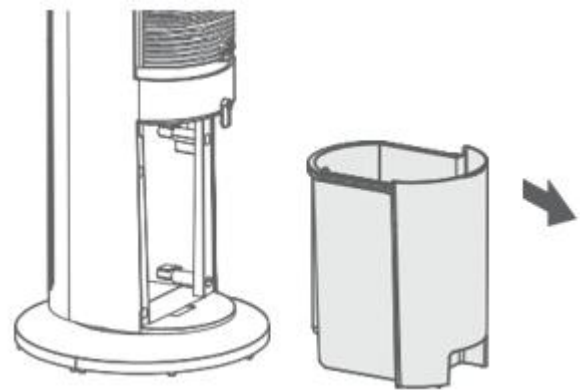

3. Turn the knob off by hand (at approximately 90° counterclockwise). Separate the water tank from the pump module (including the pipe).

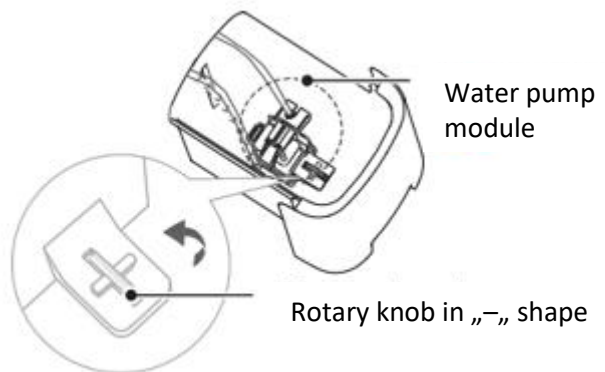

4. Clean the tank and add water in it.

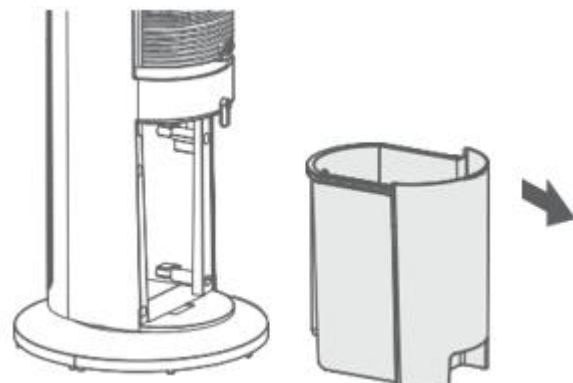

5. After cleaning and adding water to the dedicated tank, remove the pump's filter and clean it with a brush.

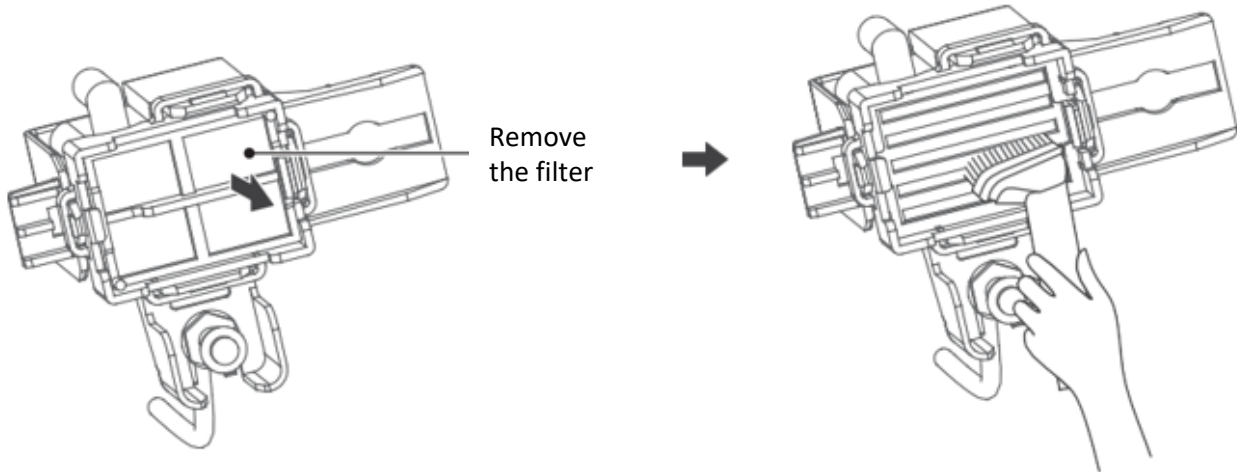

6. After feeding water or cleaning the water tank, install the water pump module in the water tank. Insert front hook into the slot of the water tank, and then rotate rotary knob in “—” shape clockwise for 90°, and close it as shown in the figure.

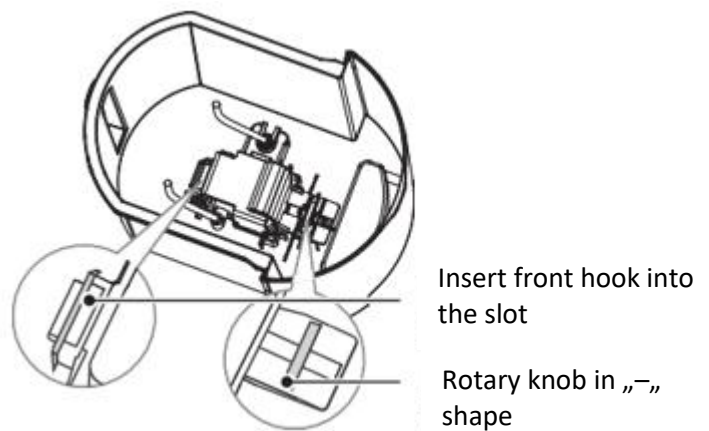

7. Push the water tank inside slowly, and stir the water tank buckle to lock it up.



## CUSTOMER CARE AND SERVICE

Always use original spare parts.

When contacting our Authorised Service Centre, ensure that you have the following data available: Model and Serial Number.

The information can be found on the rating plate. Subject to change without notice.

## TECHNICAL DATA

Voltage	100-240V~50/60Hz
Power	45W
Standby power max.	0.18W
Period for the appliance reaches automatically standby mode	N/A
When enters standby mode, it displays	N/A

Thank you for purchasing this product. If you need support with your product, visit our website using the links below.

**Get User manuals:** <https://www.heinner.ro>

**Get Service information:** <https://www.heinner.ro>



### Environment friendly disposal

You can help protect the environment!

Please remember to respect the local regulations: hand in the non-working electrical equipment's to an appropriate waste disposal center.



**HEINNER** is a registered trademark of **Network One Distribution SRL**. Other brands and product names are trademarks or registered trademarks of their respective holders.

No part of the specifications may be reproduced in any form or by any means or used to make any derivative such as translation, transformation, or adaptation without permission from NETWORK ONE DISTRIBUTION.

Copyright © 2013 Network One Distribution. All rights reserved.

[www.heinner.com](http://www.heinner.com), <http://www.nod.ro>



This product is in conformity with norms and standards of European Community.



Producer and Importer: **Network One Distribution**

Marcel Iancu Street, 3-5, Bucharest, Romania

Tel: +40 21 211 18 56, [www.heinner.com](http://www.heinner.com) , [www.nod.ro](http://www.nod.ro), [office@nod.ro](mailto:office@nod.ro)