

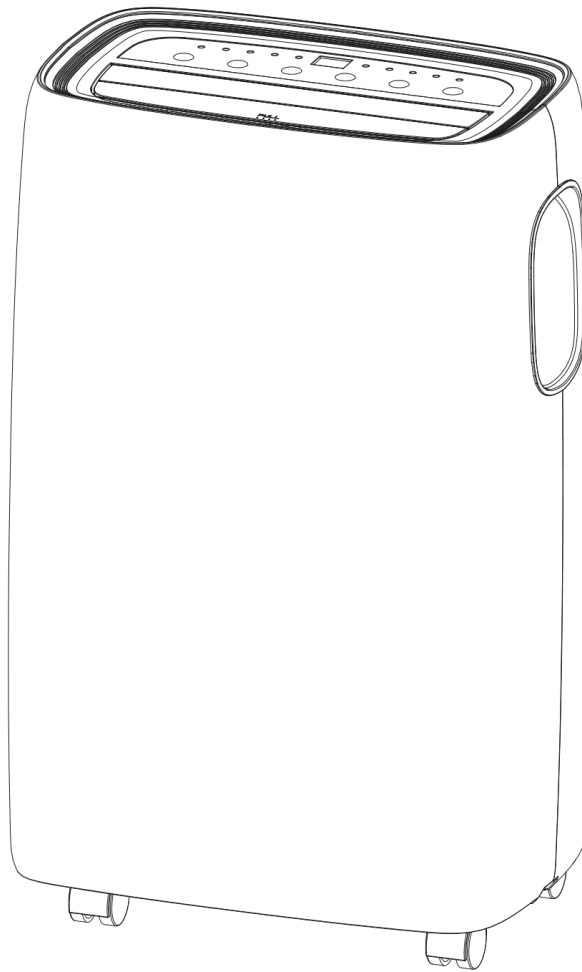

USER MANUAL



AC12000E
12,000 BTU PORTABLE AIR CONDITIONER
With WIFI Smart App

Thank you for choosing TCL.
Please read this user manual before using this innovative Air Conditioner and
keep it safe for future reference.

CONTENTS

SAFETY INSTRUCTIONS	3
FEATURES	4
PARTS LIST	5
ACCESSORIES	5
INSTALLATION	6
VENTING	7
OPERATION AND SETTINGS	8
CONNECTING THE AIR CONDITIONER TO WIFI	13
WATER-DRAINAGE	14
MAINTENANCE	15
TROUBLESHOOTING	16
APPENDIX	17

SAFETY INSTRUCTIONS

IMPORTANT!

- Carefully read the instructions before operating the unit.
- This appliance is for indoor use only.
- Rating: This unit must be only connected to a 220-240 V / 50 Hz earthed outlet.
- Installation must be in accordance with the regulations of the country where the unit is used.
- If you are in any doubt about the suitability of your electrical supply have it checked and if necessary modified by a qualified electrician.
- This air conditioner has been tested and is safe to use. However, as with any electrical appliance - use it with care.
- Disconnect the power plug from the socket before dismantling, assembling or cleaning.
- Avoid touching any moving parts of the appliance.
- Never insert fingers, pencils or any other objects through the guard.
- This appliance is not intended for use by persons (including children) with reduced physical, sensory or mental capabilities. It is also not intended for use by those with a lack of experience and knowledge, unless they have been given supervision or instruction concerning the use of the appliance by a person responsible for their safety.
- Do not leave children unsupervised with this appliance.
- Do not clean the unit by spraying it or immersing it in water.
- Never connect the unit to an electrical outlet using an extension cord. If an outlet is not available, one should be installed by a qualified electrician.
- Never operate this appliance if the cord or plug is damaged. Ensure the power cord is not stretched or exposed to sharp objects/edges.
- A damaged supply cord should be replaced by the manufacturer or a qualified electrician in order to avoid a hazard.
- Any service other than regular cleaning or filter replacement should be performed by an authorized service representative. Failure to comply could result in a voided warranty.
- Do not use the appliance for any purpose other than its intended use.
- **The air conditioner unit must always be stored and transported upright, otherwise irreparable damage may be caused to the compressor; if in doubt we suggest waiting at least 24 hours before starting the unit.**
- Avoid restarting the air conditioning unit unless 3 minutes have passed since being turned off. This prevents damage to the compressor.
- Never use the mains plug or an external timer as a switch to start and turn off the air conditioning unit. Use the provided ON/OFF button located on the control panel.
- Always place the unit on a dry and stable surface.
- This appliance should not be installed in laundry or wet rooms.

Energy Saving and Unit Safety Protection Tips

- Do not cover or restrict the airflow from the outlet or inlet grills.
- For maximum performance the minimum distance from a wall or objects should be 45cm.
- Keep the filters clean. Under normal conditions, the filters should only need cleaning once every three weeks (approximately). Since the filters remove airborne particles, more frequent cleaning may be necessary, depending on the air quality.
- For the initial startup set the fan speed to maximum and the thermostat to 4-5 degrees lower than the current temperature. After, set the fan speed to low and set the thermostat to your desired setting.
- To protect the unit we recommend not using the cooling function when the ambient temperature is higher than 35°C.

FEATURES

- Take control of your air conditioner from anywhere, at any time, using your smartphone. Simply connect the dehumidifier to your WIFI network and download the app onto your android or ios smartphone.
- The louvres close automatically when the unit is shut down, preventing dust and dirt entering the machine.
- LED screen - Indicates temperature and operation mode
- LCD Remote control
- On/Off timer function – Allows you to choose when the unit operates.
- 3 speed fan – Allowing the user to set a level between maximum air flow and quieter operation
- Self-evaporative system - no external water tank needed
- Compressor protection technology

PARTS LIST

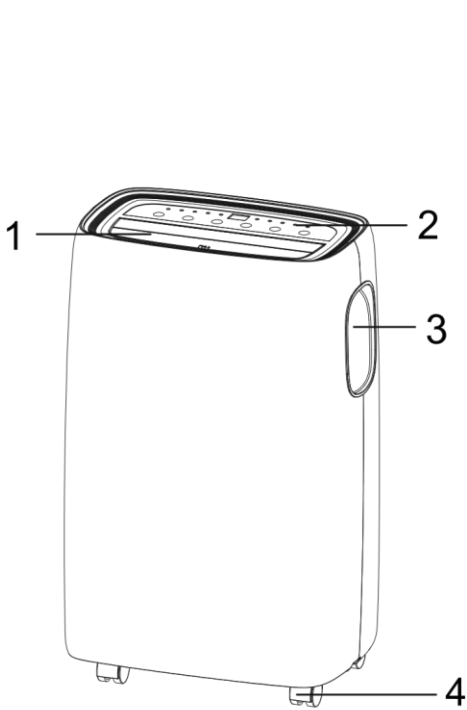

1. Deflector
2. Control panel
3. Handle (both sides)
4. Castors
5. Power cable
6. Intake grille
7. Air outlet grille
8. Intake grille
9. Condenser drain

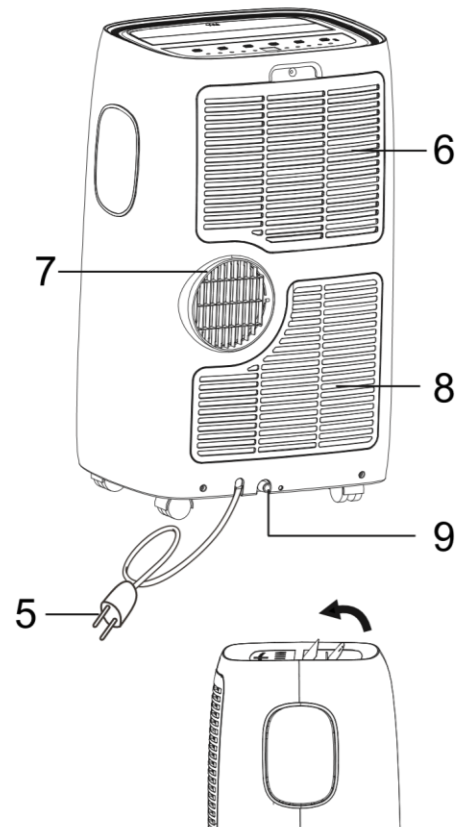

ACCESSORIES

PARTS	PARTS NAME	QUANTITY
	Exhaust hose Hose inlet Hose outlet	1 set
	Window slider kit	1 set
	Remote Control Battery	1 set

INSTALLATION

Warning: Before using this unit, please keep it upright for at least 3-4 hours. This unit can easily be moved from one room to another. While moving the unit please ensure that it is kept upright and then placed on an even surface.

1. Extend the first 10cm of each side of the hose

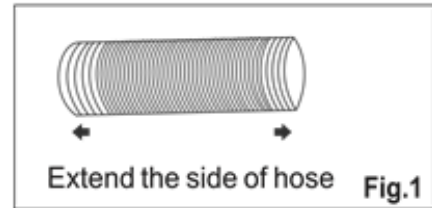
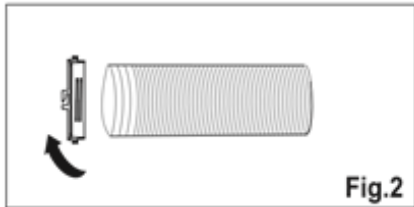

2. Screw the hose inlet onto the end of the pipe

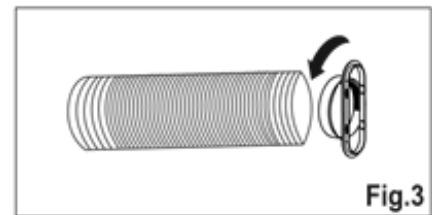

3. Screw the hose outlet to the opposite end of the hose.

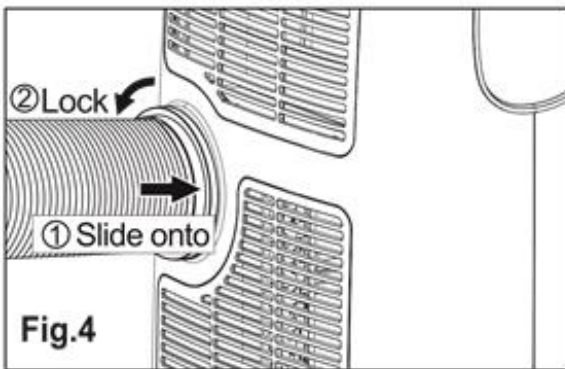

4. Put the hose inlet in position on the Air outlet grille and twist anticlockwise to lock it into place.

INSTALLATION OF WINDOW KIT

Partially open a window and then fix the window slider kit to the window as shown in the diagrams below. This method works with most standard sash or vertical sliding windows. The window kit is not designed to be used with other styles of window, although the kit may be adapted for use with other windows. Failing this the hose outlet can be used independently with most windows / doors. The window slider can be placed both horizontally or vertically, and can be extended to cover the gap. The hose outlet can then be clipped into the window slider.

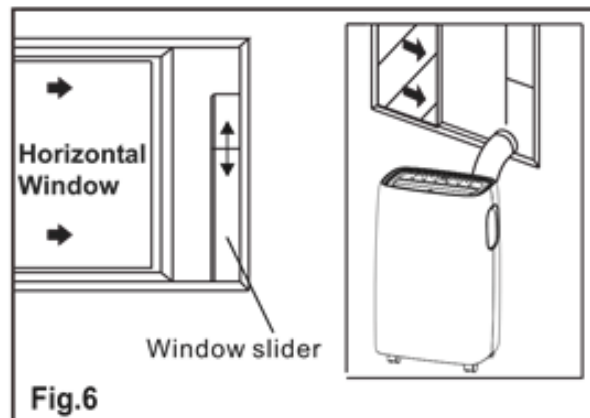
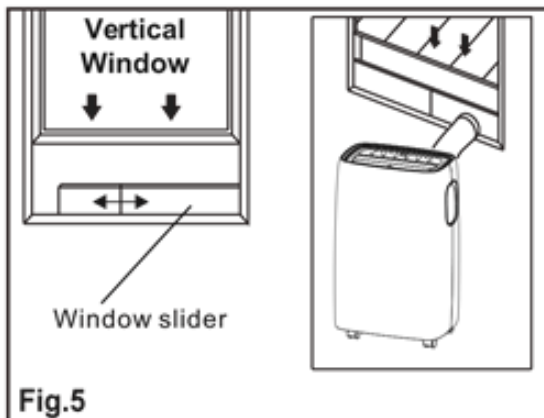

When using the window kit it should be extended to the correct length and the two parts screwed together to fix it at the length required.

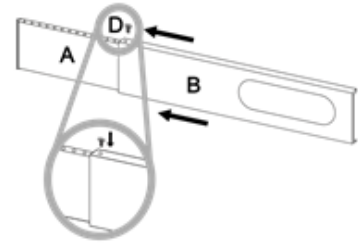

When using the *cooling mode* ensure that the opening is as small as possible. You can use curtains or other materials to block gaps in the opening.

The best form of installation is through a wall duct. If this method is chosen, we recommend that you use a self-opening draft shutter, which does not reduce the surface area of the ducting.

When used in dehumidifier mode the unit does not need venting, but please note a lot of water will be produced, and as such the unit should be set up for continuous drainage.

LOCATING THE AIR CONDITIONER

Make sure the unit is upright and vertical and there are no obstructions to the air inlets and outlet grills.

We recommend allowing 45 cm around the unit for optimal operation and unrestricted airflow.

Do not use in laundry rooms or areas where relative humidity is higher than 80%.

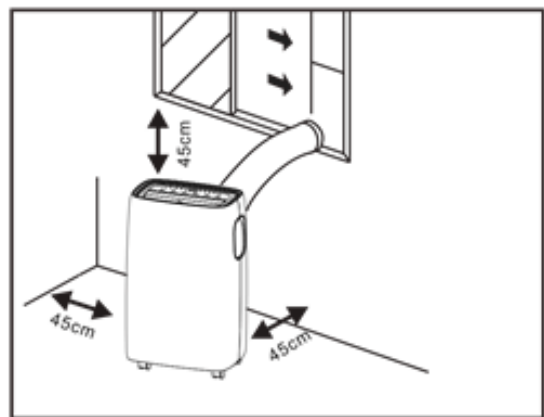

The unit should be placed on a firm level surface to minimise noise and vibration. Carpeted surfaces help reduce noise caused from the vibration of the unit during operation.

VENTING THE AIR CONDITIONER

Please make sure the vent hose is not kinked or bent. The operation of the unit will be affected if the air conditioner's airflow is obstructed.

For maximum performance, the vent pipe should be kept as straight and short as possible.

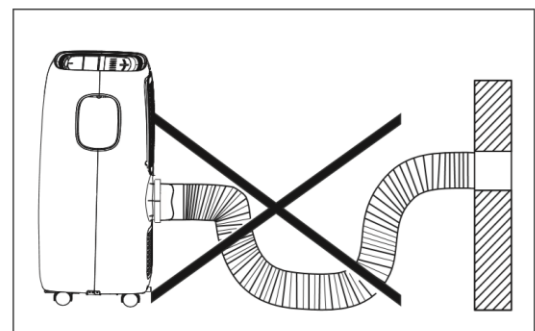

IMPORTANT SAFEGUARDS

The length of the flexible hose extends from 30 cm to 150 cm. If the hose is extended beyond this length the unit may malfunction which can invalidate the warranty. The outlet vent must be well ventilated and not obstructed as this will cause the unit to overheat. Avoid bending the air hose by more than 30°.

Before operating the unit please ensure the filters are clean and not touching the compressor coil.

Please read the full maintenance instructions including end of the season storage.

OPERATION AND SETTINGS

This portable air conditioner boasts three functions: cooling, dehumidifying and fan. The fan has three speeds: high, medium and low. The desired temperature can be set between the range of 18-32°C for cooling mode. The unit will also display operating function, temperature, fault diagnostic and protective functions on the LED screen.

CONTROL INSTRUCTIONS

When first plugged in the unit will automatically enter standby mode. The control panel on the top of the appliance enables basic control of the air conditioner. For access to all the features the remote should be used.

CONTROL PANEL

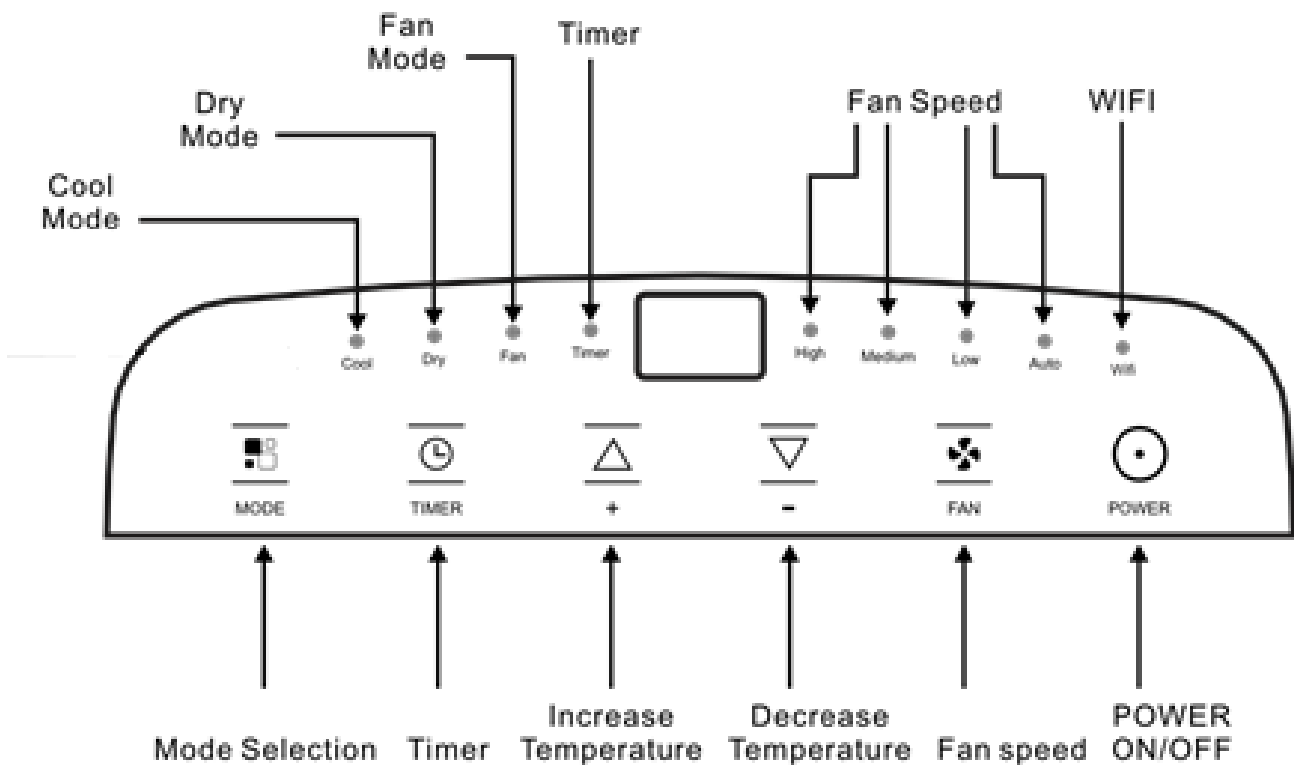

CONTROL PANEL FUNCTIONS

ON/OFF BUTTON

Press this button to turn the unit on and enter the last function that was running before the unit was turned off. Press again and the unit will switch off.

MODE BUTTON

Press this button to choose Cooling, Dehumidifying or Fan mode. The corresponding light on the display panel will illuminate to show which mode is currently set. Due to compressor protection it may take 3 minutes for the compressor to start after choosing the dry or cooling modes.

FAN SPEED BUTTON

The fan speed button should be repeatedly pressed to cycle between the available fan speeds for the mode selected. The corresponding LED will be lit to show which fan speed is selected.

IN COOLING MODE

There are 4 fan speeds available: High, Medium, Low, and Auto. In auto mode the air conditioner will adjust the fan speed depending on the difference between the ambient temperature and the temperature set. Please note changes in fan speed will be less noticeable than in the fan mode.

IN FAN MODE:

There are 3 fan speeds available: High, Medium and Low. As well as the corresponding LED showing the fan speed set, the display will also show "≡" for high speed, "==" for medium speed and "--" for low speed.





IN DEHUMIDIFY MODE:

The fan speed cannot be set manually when the unit is in dehumidifier mode, the screen will display "dH", and the dry LED will be lit.





TIMER BUTTON

The inbuilt timer will allow you to set the unit to turn on or turn off after a set period of time, Please note only one timer can be used at any time. Below 10 hours this can be set in 30 minute increments, and between 10 and 24 hours in 1 hour increments.

ON TIMER – The timer will turn on the unit automatically after the time set has elapsed. The unit will start with the same settings as when the unit was put into standby.

1. When in standby, press the  button, then set the number of hours time you desire the unit to start by pressing the  and  buttons
2. Once the set time has elapsed, the unit will turn on automatically.
3. Press the  button before the time has elapsed and the unit will turn on as normal and the timer will be cancelled
4. The function and fan speed can be set by turning the unit on, choosing the settings and then putting the unit into standby before setting the timer.

OFF TIMER – The timer will turn off the unit automatically after the time set has elapsed.

1. While the unit is operating, press the  button and then set how long you require the unit to run by pressing the  and  buttons.
2. Once the set time has elapsed, the unit will turn off automatically.
3. If the  button is pressed before the time has elapsed, the timer will be cancelled and the unit will turn off.

REMOTE CONTROL

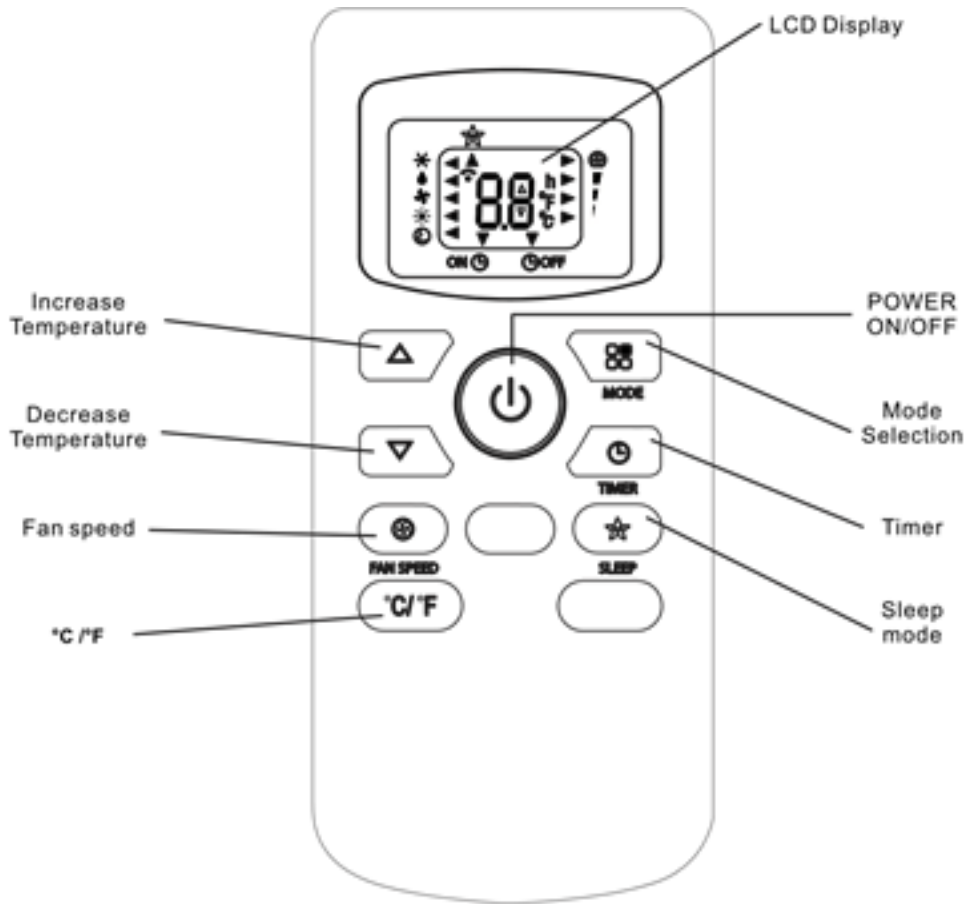

⏻ POWER ON/OFF BUTTON

Press this button to turn the unit on/off.

▲ UP BUTTON

Used to increase the desired temperature in cooling mode, or increase the time set in the timer

▼ DOWN BUTTON

Used to decrease the desired temperature in cooling mode, or decrease the time set in the timer

🌀 MODE SELECTION BUTTON

Press this button to cycle through the operational modes of the air conditioner. The mode chosen will be shown by an arrow on the left hand side of the screen on the remote.

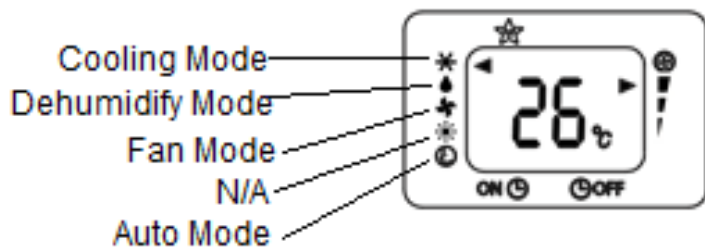

The remote has auto mode in addition to the options found on the air conditioner, which will aim for a temperature of 23°C, above this temperature the unit will operate in cooling mode, and below this temperature the unit will operate in fan mode.

🕒 TIMER BUTTON

The timer button on the remote offers the same functionality as the timer button on the main unit.

ON TIMER – The timer will turn on the unit automatically after the time set has elapsed. The unit will start with the same settings as when the unit was put into standby.

1. When on standby, press the 🕒 button twice, the display will show a ▼ at the bottom next to “ON 🕒”
2. Set the number of hours time you desire the unit to start by pressing the ▲ and ▼ buttons
3. Once the set time has elapsed, the unit will turn on automatically.
4. Press the ⏸ button before the time has elapsed and the unit will turn on as normal and the timer will be cancelled
5. The function and fan speed can be set by turning the unit on, choosing the settings and then putting the unit into standby before setting the timer.



OFF TIMER – The timer will turn off the unit automatically after the time set has elapsed.

1. While the unit is operating, press the 🕒 button, the display will show a ▼ at the bottom next to “OFF 🕒”
2. Set how long you require the unit to run by pressing the ▲ and ▼ buttons.
3. Once the set time has elapsed, the unit will turn off automatically.
4. If the ⏸ button is pressed before the time has elapsed, the timer will be cancelled and the unit will turn off.



🌀 FAN SPEED BUTTON

The Fan speed button allows you to cycle through the available fan speeds for the mode selected. In fan mode the available options are Low, Medium and High. In cooling mode an auto fan speed is also available, which will adjust the fan speed depending on the difference between the temperature of the room, and the desired temperature set. In dehumidifier mode it is not possible to amend the fan speed.

The fan speed selected will be shown on the right hand side of the display.

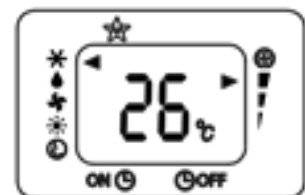
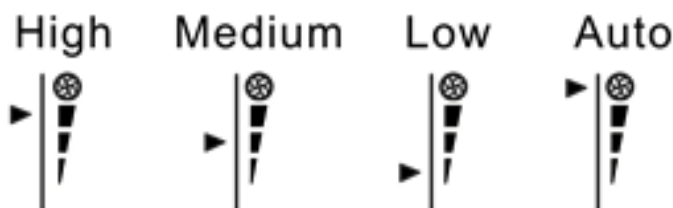



°C/°F TEMPERATURE UNIT BUTTON

Press this button to change the display between showing the temperature in °C and °F

★ SLEEP BUTTON

This function is useful for night as it gradually reduces the operation of the air conditioner when running in cooling mode. The air conditioner will run with a low fan speed and the desired temperature will increase by 1°C per hour for two hours (i.e max of 2°C above temperature originally set). The unit will then continue to run set at this temperature for a further 6 hours before entering standby mode.

To operate the sleep mode press the ★ button and a ▲ will be displayed under the icon on the display.

The sleep mode can be cancelled at any time using the Sleep ★ , Mode  , or Fan Speed  buttons.

INSERTING OR REPLACING THE BATTERIES

- Remove the cover on the rear of the remote control.
- Insert two “AAA” 1.5V batteries ensuring they are in the correct position.
- Replace the battery cover.



MULTI PROTECTIVE FUNCTIONS

ANTI-FREEZE PROTECTION

When the ambient temperature is low while in Cooling Mode, the compressor and water motor will stop working if the copper coil temperature reaches <math><2^{\circ}\text{C}</math> for over 20 seconds. When the copper coil temperature increases to $>8^{\circ}\text{C}$, the protection will be stopped automatically. During this operation “Lt” will be displayed on the unit.



WATER-FULL PROTECTION

When the water level in the internal water tank is surpassing the maximum level, the unit will alert automatically and “Ft” will show on the LED screen. Please discharge water from the machine according to “Water Drainage” instructions



COMPRESSOR DELAY-PROTECTION

The compressor runs under a 3 minute delay protection function and so it can take 3 minutes after cooling or dehumidifying mode has been selected before the compressor starts to run.

COMPRESSOR PROTECTION

In cooling and dehumidifying modes if the temperature difference between the coil temperature and room temperature is less than 3°C, for more than 30 minutes, the machine will enter ‘no refrigerant’ compressor protection mode. The compressor and water pump motor will stop working. Normal operation will resume in due time.

CONNECTING THE AIR CONDITIONER TO WIFI

Ensure whilst setting up the WIFI on your air conditioner, that it is close to your router, as the unit requires a good signal during the setup process. Your air conditioner is designed to be connected to a 2.4ghz network, and the connection is set up using the TCL “SMART LIFE” app. We would advise on using the QR codes below to ensure the correct app is downloaded.



Android



IOS

You can use the unit together with other Tuya smart devices by using the “Smart Life” app by TUYA which is also available on the app store, although some features may be limited so would advise on using the version above which is optimised for use with your air conditioner.

Further details on how to connect the device can be found in the separate WIFI Guide.

WATER-DRAINAGE

MANUAL DRAINAGE:

When the internal water tank is full the unit will stop working and Ft will show on the LED screen.

- Shut off the unit and unplug. Try not to move the model abruptly as this may cause water to spill out from the internal water tank.
- Place a tray under the bottom water plug as shown in the image.
- Unplug the drain cap - water will drain from the internal water tank.
- Put the drain back.

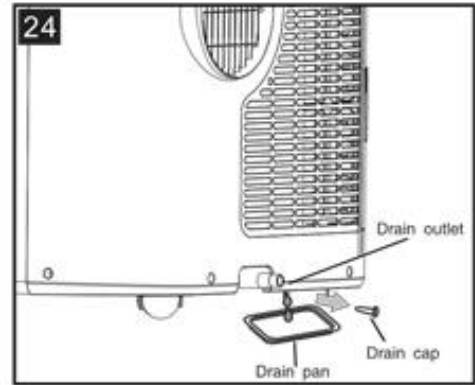

CONTINUOUS DRAINAGE:

- Remove the drain plug
- Use a water pipe (1/2" or 12.7mm) connected to the drain outlet.
- You can plumb this pipe into your current plumbing system, lead it outside or use an external water pump

NOTE: The drain is gravity fed, and so no part of the drain hose can be higher than the drain outlet, otherwise the tank will not drain.

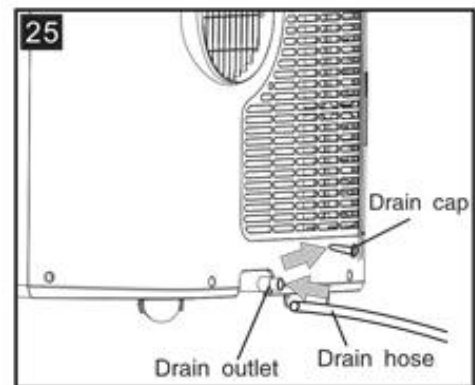

Notes:

- This model has a self-evaporative function, which reduces the need to empty the water tank. Please ensure the rubber bung is in position if using the self-evaporation function. If the unit is vented correctly, in cooling mode most of the water is reused to cool the condenser coil and any excess is evaporated.
- If using in dehumidifier mode we recommend for the unit to be set up with continuous drainage.
- If the unit is used in cooling mode as self-evaporating air conditioner the internal tank may still fill quicker than expected if the humidity in the air is very high or if the unit is vented incorrectly. We recommend emptying the unit using the drain port in such an instance or use continuous drainage as described above.
- Make sure the filters are cleaned regularly as described in this user manual.

MAINTENANCE

CLEANING

Please shut off the unit and unplug from the mains before cleaning or performing any maintenance

CLEAN THE SURFACE

- Clean the plastic housing with a duster or a soft wet cloth.
- Do not use chemical solvents (such as benzene, alcohol or gasoline) as they may cause irreversible damage.

AIR FILTER CLEANING

- a) Clean the air filters every 2 weeks. If the air filter is blocked with dust, the unit's performance will be significantly affected.
- b) Use a vacuum cleaner to remove the dust from the filter
- c) For a deeper clean, wash the air filter by immersing it in warm (about 40°C) water with a neutral detergent.
- d) Rinse it and then dry it thoroughly.
- e) Carefully re-install air filter

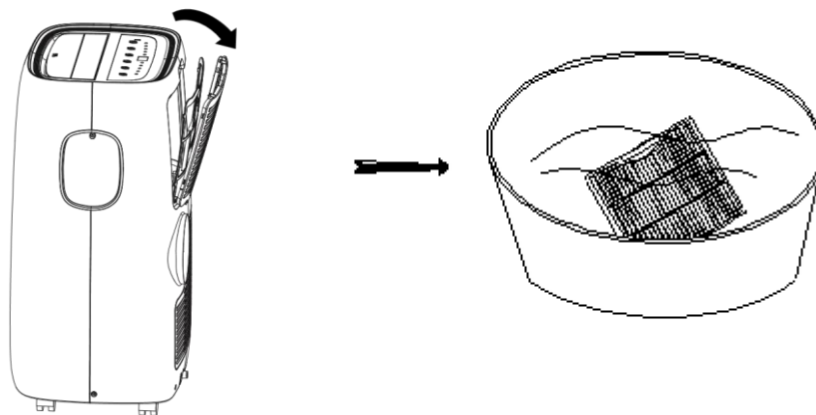

END OF SEASON MAINTENANCE

1. Pull out the plug from the bottom drainage hole and empty the internal tank. You can also drain the water by leaning the unit.
2. Switch the unit to Fan mode, and select low fan speed.
3. Keep the unit in this mode for 6-12 hours - until the conduit is dried. Doing this helps to keep the inside of the unit dry and prevents mould developing
4. Turn off the unit and pull out the plug.
5. Coil the wire and bind it together, then put it into the accessories space.
6. Separate the vent pipe and store it safely.
7. Cover the unit and keep it in a dry place.
8. Take the batteries out of remote control and store, or dispose, them safely

TROUBLESHOOTING

Do not repair or disassemble the unit by yourself, unauthorized repair attempts will invalidate the warranty and may cause bodily harm.

Trouble	Reason	Solution
The unit does not work	No power supply	Power-on and turn on the unit.
	Ft displayed on screen	Drain the internal water tank
	Timer function is active	Cancel Timer function
	Room temperature too low or too high	Use only in ambient temperatures between 5-35°C
The unit does not seem to perform.	In direct sunlight	Draw the curtains, UV affects performance
	Windows or doors open. Large amount of people or a heat source in the room.	Close windows and turn on another air conditioner
	Filter is very dirty	Clean or change the air filter
	Air inlet or air outlet is blocked	Clear out debris
	Room temperature is lower than the desired temperature set	Change the desired temperature set
The unit is loud	The unit is not sited on flat surface	Put the unit on flat surface. Carpet under the unit can prevent vibrations.
Compressor does not work	Overheating protection is active	Check venting. Restart the unit after 5 minutes when the compressor has cooled
Remote control doesn't work	Operating distance is too far.	Move the remote control closer to the unit and make sure it is aimed at the air-outlet grille
	Control panel has not received the signal from remote control.	
	The batteries are flat	Replace the batteries
Ft on LCD	Water tank is full inside the machine	Drain out water from the drain port at bottom rear of the unit.
Pf on LCD	Room temperature is abnormal	Temperature not within 5-35 C operating range. If temperature within operating range clean the filters
Lt on LCD	Anti-freezing protection	Waiting for defrosting. Function will recover automatically. No user input needed.
	High pressure protection	After inside gas pressure comes down, it will function normally. No user input needed
	Water leakage	Internal blockage. Clean filters. Use permanent drainage if very humid environment or in heating/ dehumidifier mode

If the above solutions do not resolve the problem please contact the service centre.

APPENDIX



Disposal: Do not dispose this product as unsorted municipal waste. Collection of such waste must be handled separately as special treatment is necessary.

Recycling facilities are now available for all customers at which you can deposit your old electrical products. Customers will be able to take any old electrical equipment to participating civic amenity sites run by their local councils. Please remember that this equipment will be further handled during the recycling process, so please be considerate when depositing your equipment. Please contact the local council for details of your local household waste recycling centres.

TECHNICAL DATA

Capacity	3.35 kWh / 12,000 BTU
Rated Current	5.5 A
Rated Input	1.28 kW
Maximum input power	1.4 kW
Maximum input current	6.7 A
Air Flow	330 m ³ /h
Noise	54dB(A)
EER	2.6
Max Noise Level (Sound Pressure)	65 db
Max Noise Level (Sound Energy)	54 db
Energy Rating (Cooling/ Heating)	A
Maximum Suction Pressure	2.1 MPa
Maximum Allowable Pressure	4.2 Mpa
Refrigerant	R410A / 0.5 kg
Power Supply	220-240V~/50Hz
Net Weight	31 kgs
Gross Weight	35 kgs
Net Dimension(W*D*H)	445*375*720mm
Gross Dimension(W*D*H)	485*405*865mm
Unit must be vented outside when in Air Cooling mode. For the purposes of EU regulation EN12102 this is a <i>local air conditioner</i> and produces less than 65dB(A) sound energy.	

TCL UK SUPPORT

Please, for your own convenience, make these simple checks before calling the service line.

If the unit still fails to operate call: 0871 620 1057 or complete the online form

1. Has the unit been standing upright for at least 2 hours?
2. Is the unit plugged into the mains?
3. Is the fuse OK?
4. Switch the unit off and wait three minutes to see if the issue is resolved. Restart the unit.
5. Check if the water tank is full.

Office hours: 9AM - 5PM Monday to Friday

TCL AIR CONDITIONING
Unit J6, Lowfields Business Park
Lowfields Way, Elland
West Yorkshire, HX5 9DA