



EN

DEHUMIDIFIER

DRY PURY 11 – 13 – 17 – 21 – 25



OPERATING INSTRUCTIONS

Read the instructions carefully before operating or servicing the dehumidifier.
Observe all the safety instructions; failure to observe the instructions may lead to accidents and/or damage.
Keep these instructions in a safe place for future reference.



Appliance is filled with flammable gas R290.



Before installing and using the appliance, read the owner manual.



Before installing the appliance, read the installation manual.



Any repairs you need, contact the nearest authorized Service Centre and strictly follow manufacturer's Service Manual.

The Refrigerant R290

- To realize the function of the air conditioner unit, a special refrigerant circulates in the system. The refrigerant is the fluoride R290 = 3 GWP (Global warming potential). This refrigerant is flammable and inodorous. It can lead to explosions under certain conditions, however the flammability of this refrigerant is very low and it can be ignited only by fire.
- Compared to other common refrigerants, R290 is a non-polluting refrigerant with no harm to the ozonosphere and a no effect upon the greenhouse effect. R290 has very good thermodynamic features which lead to a really high energy efficiency. The units therefore need less filling.

Warning:

Do not try to accelerate the defrosting process or to clean the appliance in different ways other than those recommended by the manufacturer. Should repair be necessary, contact your nearest authorized Service Centre. Any repairs carried out by unqualified personnel may be dangerous. The appliance has to be stored in a room that doesn't have any continuously operating ignition sources. (for example: open flames, an operating gas appliance or an operating electric heater.) Do not pierce or burn.

Appliance has to be installed, used and stored in a room with a floor area larger than 4 m². For repairs, strictly follow manufacturer's instructions only for appliances filled with R290 flammable gas. Be aware that refrigerants do not have any odour.



Exception Clauses

Manufacturer will bear no responsibilities when personal injury or property loss is caused by the following reasons.

1. Damage the product due to improper use or misuse of the product;
2. Alter, change, maintain or use the product with other equipment without abiding by the instruction manual of manufacturer;
3. After verification, the defect of product is directly caused by corrosive gas;
4. After verification, defects are due to improper operation during transportation of product;
5. Operate, repair, maintain the unit without abiding by instruction manual or related regulations;
6. After verification, the problem or dispute is caused by the quality specification or performance of parts and components that produced by other manufacturers;
7. The damage is caused by natural calamities, bad using environment or force majeure.

GENERAL OPERATING AND SAFETY INSTRUCTIONS

- **This appliance is a highly efficient dehumidifier, designed for domestic use only!**
- Use this dehumidifier only as outlined in this manual. Any other use not recommended by the manufacturer may cause fire, electric shock or malfunctions.
- The unit contains refrigerant; keep it vertical at all times.
- Once you have opened the unit, keep it vertical to allow the refrigerant to stabilise and wait two hours before operating it.
- Ensure that the required voltage and frequency (220-240V/50Hz) match the available power source.
- This appliance can be used by children aged from 8 years and above and people with reduced physical, sensory or mental capabilities or lack of experience and knowledge if they have been given supervision or instruction concerning use of the appliance in a safe way and understand the hazards involved.
- Children shall not play with the appliance.
- Cleaning and user maintenance shall not be made by children without supervision.
- Make sure the plug is inserted fully. Do not use multiple adapters. Do not touch the plug with wet hands. Make sure the plug is clean.
- Children aged between 3 and 8 years must only be able to turn the appliance on/off, provided that the appliance has been placed in its normal operating position, that instructions have been given on how to use the equipment safely, and that its risks have been understood.
- Children aged between 3 and 8 years must not be able to plug in, adjust, clean or perform any maintenance on the appliance.
- **Disconnect the mains power when the appliance is not in use or during cleaning operations. Keeping the appliance plugged in may cause electric shocks or accidents.**

- To disconnect the appliance, set the switch to OFF and remove the plug from the socket. Only pull on the plug. Do not pull the cord.
- Do not bend, drag or twist the cord, or apply force to remove it. **Do not operate the unit if its cable or plug are damaged; doing so can cause fires or electric shock.** If the power cord is damaged, it must be replaced by a service centre.
- Do not place heavy objects on top of the appliance.
- Do not place the appliance on the carpets, any water leakage could damage them.
- To prevent water spills, empty the water tank before moving the appliance.
- Do not tilt the dehumidifier onto one side or turn it upside down, as the water which runs out could damage the appliance.
- **Do not operate the unit on unstable or sloping surfaces: water leaks can cause it to malfunction or cause excessive vibration and running noise.**
- The dehumidifier must be positioned **at least 50 cm** away from the wall or other obstacles, so that the heat can dissipate correctly.
- **Close all open windows to maximise dehumidification efficiency.**
- **Do not insert objects or sharp instruments into the air outlet grille.**
- **Do not cover the air intake and outlet grilles in any way.**

WARNING!

In the event of an anomaly, switch the appliance off and unplug it immediately. Do not dismantle, repair or modify this product freely. In the event of a malfunction, contact the after-sales service centre directly.

- Do not immerse the power cord, plug or any other part of the appliance in water or other liquids.
- Do not expose the dehumidifier to direct sunlight.

- Do not use the appliance in the bathroom or laundry room.
- Keep the appliance well away from sources of heat which could cause plastic parts to become warped.
- Do not spray insecticides, oils or paints near the appliance; doing so may damage its plastic parts or start a fire.
- **Keep flammable gases and oils away from the appliance!**
- **Do not move the appliance while it is operating; doing so can cause leaks and malfunction.**

DESCRIPTION OF PARTS

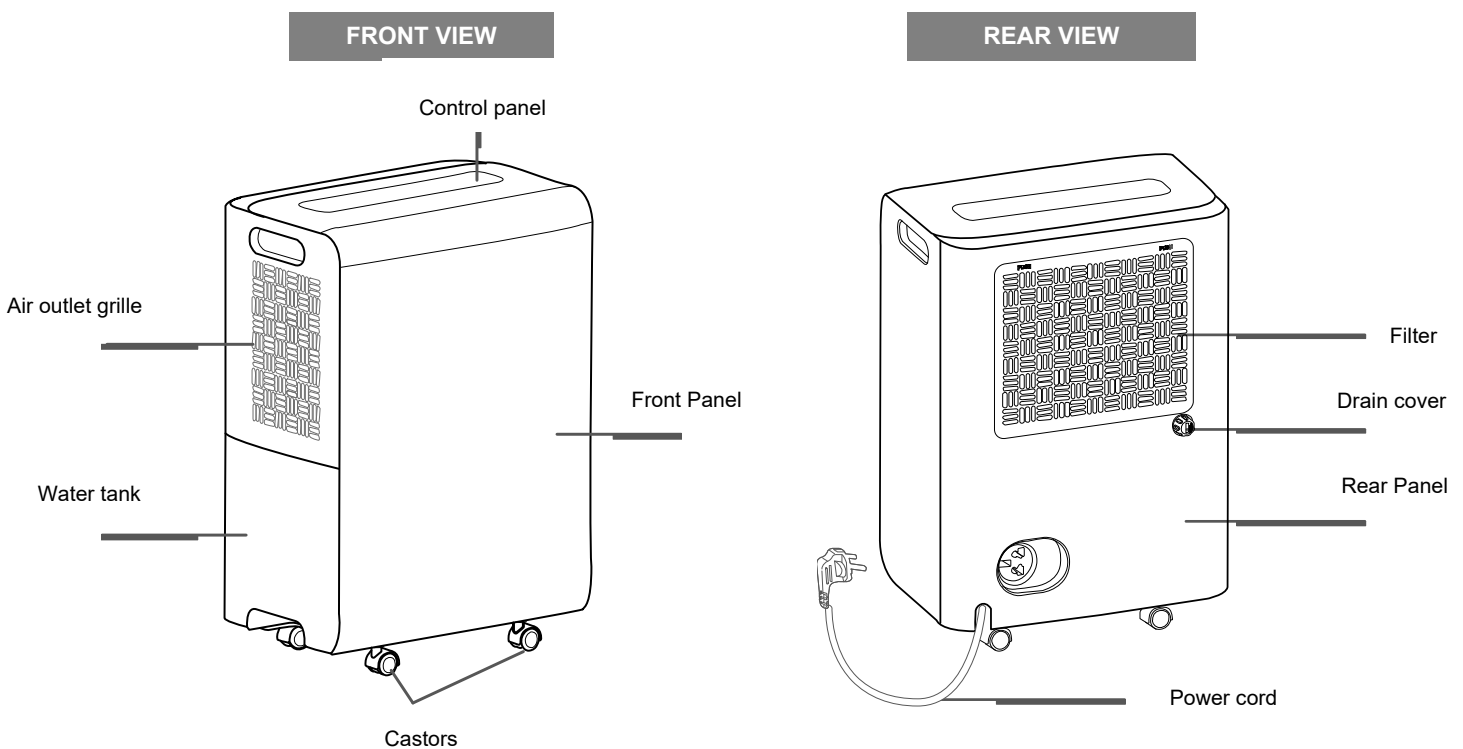

The following space must be maintained to ensure the operating efficiency of the dehumidifier.

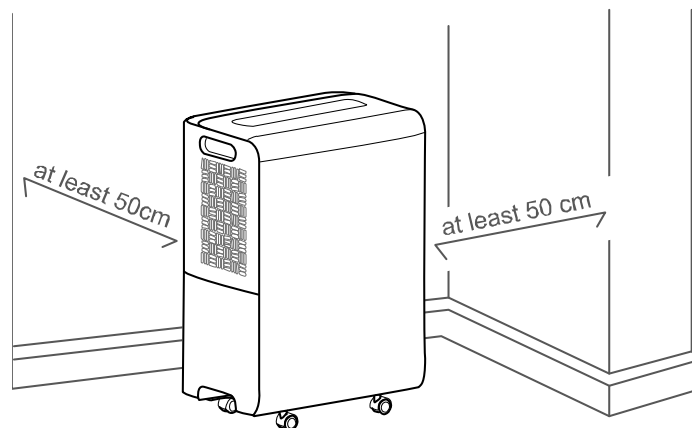

PRE-OPERATING CHECKS AND OPERATIONS

Before operating the appliance, check the correct positioning of the float inside the condensate collection tank.

1. Remove the tank following the direction of the arrow.
2. Remove from the tank the bubble plastic bag which contains the 4 wheels and the cable reel
3. Reposition the tank, closing it perfectly, as shown below

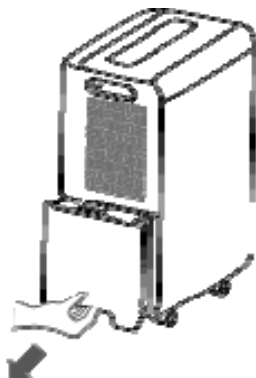

4. Check that the float inside the tank for collecting the condensate is correctly positioned. During transport it may undergo small displacements.

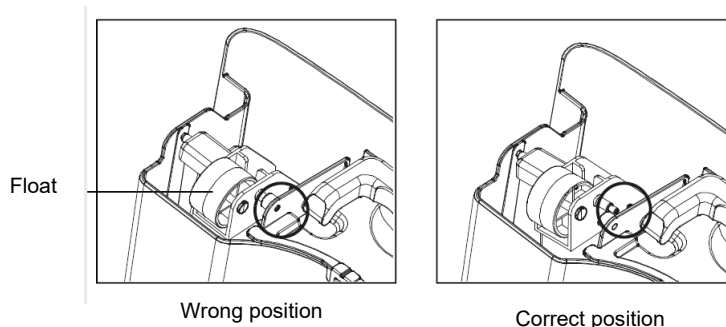

5. Reposition the water tank, closing it perfectly
6. Tilt the dehumidifier no more than 45° and remove the 4 rubber plugs, which will be replaced by 4 wheels that are inside the tank.
7. Position the wheels on the 4 holes and push until the wheels are set firmly in place.

OPERATING INSTRUCTIONS

APPLIANCE START-UP

Place the product on a flat and stable heat-resistant surface, at least 1 metre away from flammable or heat-sensitive materials and 50 cm away from walls or other obstructions.

Make sure the water tank is in the correct position.

Connect the power cord to a suitable electric socket (220-240V/50Hz).

Turn the appliance on with ON/OFF on the control panel.

The unit emits a “beep” signal and the corresponding LED lights up.

The dehumidifier is designed to operate at ambient temperatures from **+ 5°C to + 32°C**.

If it is operated at low temperatures, ice may form on the evaporator, degrading its operation.

When this happens, the dehumidifier goes into defrost mode. The compressor stops, but the fan continues running.

The defrosting operation may start up and operate for some minutes; during the defrosting operation, the dehumidification function may intermit: please don't turn off the switch or pull out the power plug of the dehumidifier.

We recommend not using the dehumidifier in room temperatures lower than 5°C.

Do not remove the tank when the unit is in operation.

If you wish to make continuous draining of condensate, follow the instructions in the dedicated paragraph.

This dehumidifier is equipped with a composite filter for air purification consisting of 3 filters:

Green filter - Catechin filter natural substance extracted from tea, eliminates odors and pollutants

Gray filter - Silver ion filter, eliminates bacteria

Blue filter - Additional filter with anti-bacterial action

The dehumidifier is equipped with a signaling system for the need to clean the dust filter after 250 hours of operation (AIR CLEAN SYSTEM).

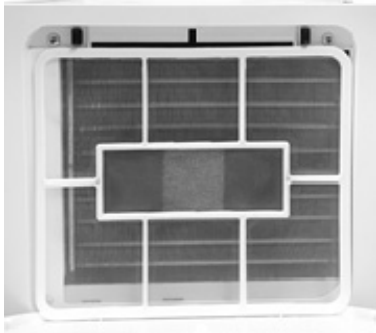

OPERATING PRECAUTIONS

The appliance will only start operating if the humidity level in the room is above the set value.

The dehumidifier will continue to operate until the set humidity level has been reached, **with the exception of interruptions caused by a full tank**. In this case, empty and reinstall the tank: the dehumidifier will now start running again.

WARNING:

After each interruption of its operation, at least 3 minutes must pass before the dehumidifier starts up again: this delay prevents the compressor being damaged.

If, on the other hand, the set humidity percentage is higher than the level currently found in the room, the dehumidifier will not start.

If, after following the appliance start-up instructions, **the dehumidifier does not start and the stand-by (POWER) LED does not come on**, or if the dehumidifier stops for no reason, make sure the plug and power cord are in good working order. After doing so, wait for 10 minutes and then restart the appliance.

If the dehumidifier still does not start after 10 minutes, or if either the power cord or plug are damaged, switch off the appliance and contact an after-sales service centre.

WARNING:

When the dehumidifier is running, the compressor produces heat and the appliance emits warm air into the room. The room temperature will therefore tend to increase. This is completely normal.

TURNING THE DEHUMIDIFIER OFF

To turn the dehumidifier off press the POWER button.

The power supply stops and the compressor stops, even if the ventilation function continues for about 3 minutes, before stopping, then the dehumidifier stops working. Unplug the appliance if you do not intend to use it for some time.

HOW TO ELIMINATE CONDENSATE

The water extracted from the air can be collected in the provided water tank.

When the tank is full, not inserted or not correctly inserted, the FULL TANK led turns on and the unit beeps for about 10 seconds, at the end of which the unit turns off.

Do not use remove the water tank while unit is in operation or if it has just been turned off.

To switch off the appliance, press POWER button and wait a few seconds.

1. Carefully remove the tank and following the direction of the arrow, paying attention to not spill out the water from the tank and then splash onto the floor.

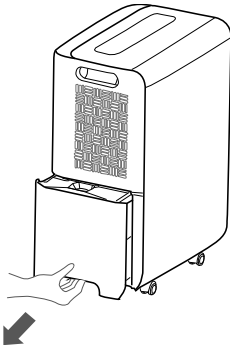

2. Empty the tank.

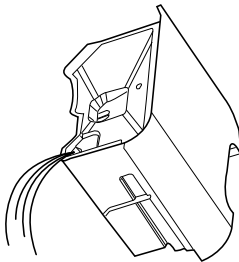

3. Reposition the tank following the direction of the arrow.

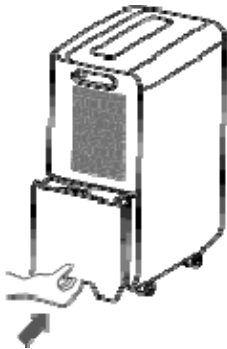

N.B.

Do not use the drain hose when you are collecting condensation in the tank, otherwise water can leak out of the hose.

CONTINUOUS CONDENSATE DRAINAGE

The water can be continuously drained when using a PVC hose with an inner diameter of 14 mm (not supplied). Turn off the appliance and remove the plug before connecting the hose.

Unscrew the drain plug and remove the rubber plug from the unit. Screw the adapter to the unit and firmly connect the PVC hose, making sure it is positioned downwards to allow water to drain. Place a basin under the hose for collecting condensation water. Be careful not to bend the hose otherwise the water cannot be drained.

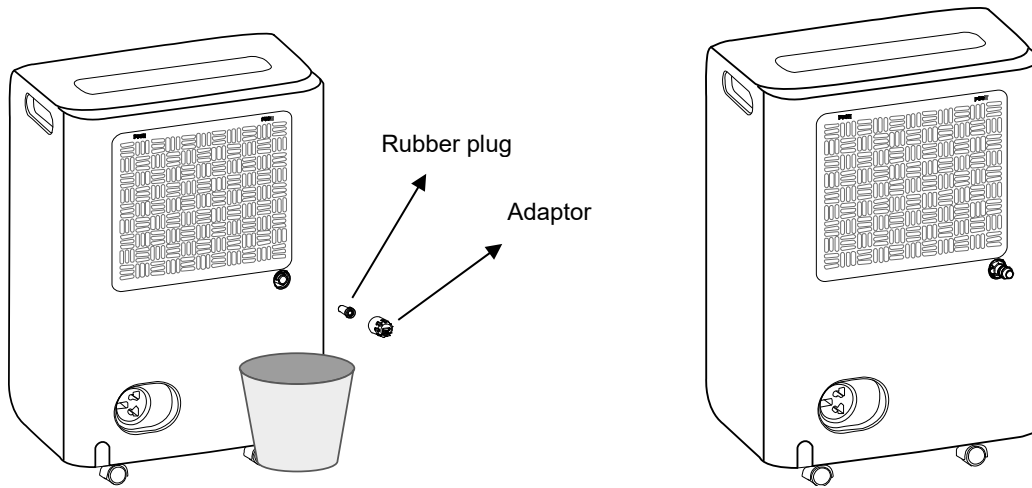

The height of the drainage hose must not exceed that of the hole: do not block the drainage hose exit.

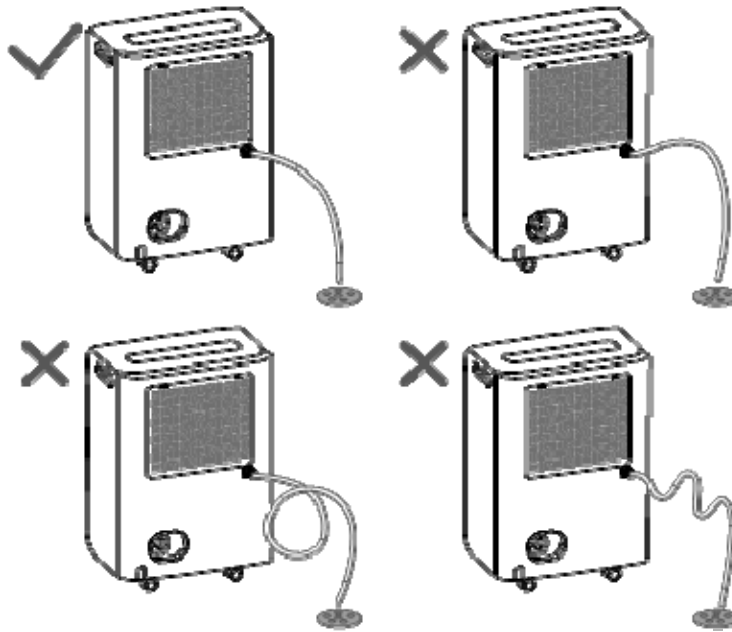

When disconnecting the tube, prepare a container to collect the remaining water from the tube.



CONTROL PANEL

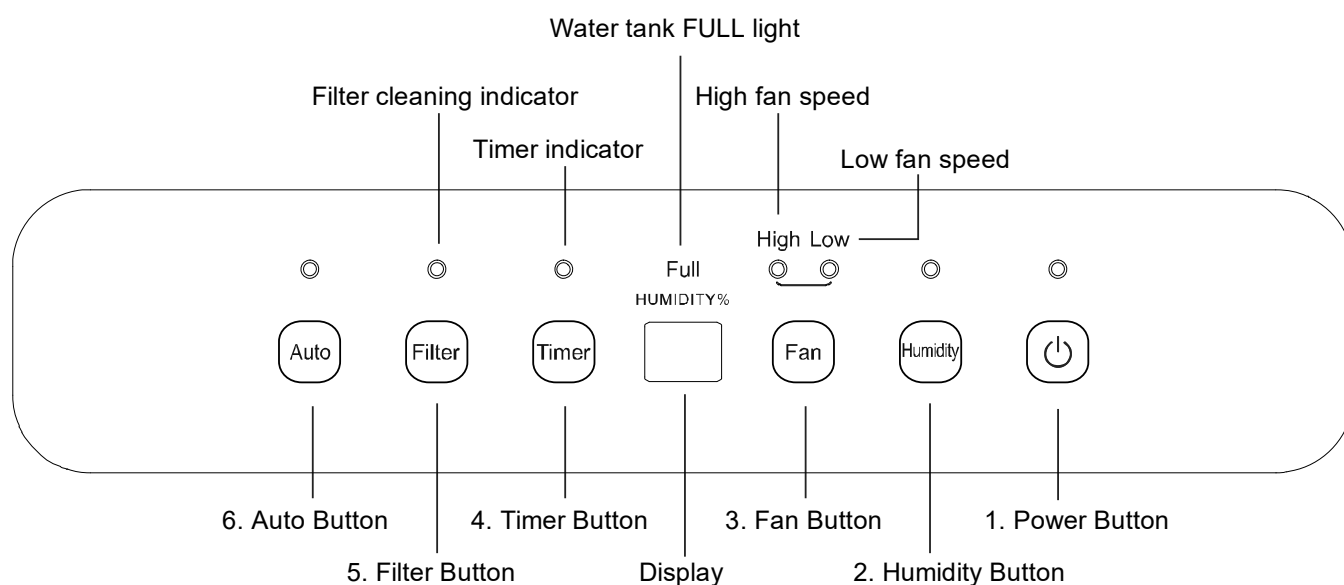

Each time the button is pressed, the unit emits an auditory signal.

BUTTONS & LEDS

1. **POWER BUTTON:** press this button to turn the dehumidifier on and off.
2. **HUMIDITY BUTTON:** press this button to adjust the % of humidity to desired value (30-80%) – each step 5%
3. **FAN SPEED BUTTON:** press this button to adjust the ventilation speed (Low or High). When you need fast dehumidification, select high fan speed, when you need the unit to work quietly, select low fan speed.
4. **TIMER BUTTON:** To program the switching on or off of the appliance. the Timer can be set in the 1-24 hours sequence
5. **FILTER BUTTON:** After 250 hours of operation, the FILTER led turns on to indicate that it is time to clean the filter. Take the filter out and clean it. Then press the FILTER button.
6. **AUTO BUTTON:** Press this button to set the automatic dehumidification mode, when the appliance enters this mode it automatically sets the most comfortable humidity. To exit the automatic dehumidification, just select the humidity with the appropriate button.

DISPLAY

The display shows the humidity present in the environment. Press the Humidity button to select the desired humidity. 5 seconds later it will return to show the humidity detected in the environment.

LED Filter: filter needs to be cleaned.

LED HIGH AND LOW FAN SPEED : it shows the set fan speed: High and Low.

LED TIMER: it shows that the timer is set (sequence 1-24 hours)

LED Full: When the tank is full or it's not correctly positioned the LED Full comes on and flashes, the appliance stops running. A 10 second beep sounds. Remove the tank and empty it (as indicated in "HOW TO ELIMINATE CONDENSATION"), the restore it; the dehumidifier will start running again.

DEFROST: the dehumidifier is designed to operate at ambient temperatures from **+ 5°C to + 32°C**.

If it is operated at low temperatures, ice may form on the evaporator, degrading its operation.

When this happens, the dehumidifier goes into defrost mode. The compressor stops, but the fan continues running.

We recommend not using the dehumidifier in room temperatures lower than 5°C.

MEMORY FUNCTION: the dehumidifier starts up again after a power failure keeping last settings.

AUTOSTOP FUNCTION: if the humidity it's lower than 5% respect to the one set by the humidifier automatically it stop.

CLEANING AND MAINTENANCE

MAINTENANCE OF THE HUMIDIFIER'S EXTERIOR SURFACE

⚠ Warning

Always pull the dehumidifier's plug out of the power socket before cleaning it, to prevent electric shock and malfunction.

⚠ Warning

Do not wet the appliance or immerse it in water, otherwise electric shocks may occur.

Use a damp and soft cloth to clean the exterior surface of the dehumidifier.

Do not use solvents, petrol, xylene, talcum powder or brushes to clean the unit: these may damage the surface or colour of the casing.

CLEANING OF GRILLE AND EXTERIOR SURFACE

To clean the external surface, use a soft cloth. If it is particularly dirty, use a damp cloth, taking care to dry the surface. To clean the air supply grille, use a vacuum cleaner or a soft brush.

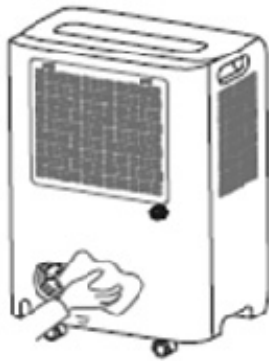

CLEANING THE WATER TANK

We advise removing the tank once every few weeks to prevent mould and bacteria forming on it. Fill the tank with clean water a small amount of detergent; swill the water around in it, then it out and rinse it thoroughly.

CLEANING THE AIR FILTER

The function of the filter is to filter the dust or dirt present in the air. If the filter is blocked by dust, the electrical consumption will be higher than normal.

Do not operate the dehumidifier without having positioned the filter, this could damage the appliance.

The filter should be checked and cleaned at least after 250 hours of operation, or more frequently if necessary.

Cleaning instructions:

Remove the filter by pressing simultaneously on "push" at the top left and right of the filter with 2 hands. Clean the filter with water (the water temperature must not be higher than 45 °C) and let it dry naturally. Place the filter back in its housing.

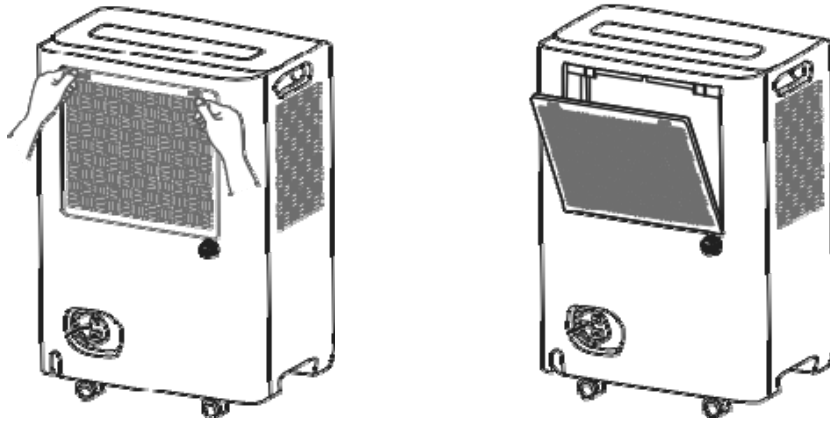

Do not dry the filter with a heat source or with a hairdryer, it could catch fire. Use a vacuum cleaner with the lowest possible power to avoid damaging the fibers. It is advisable to clean the filter every 3 months or more frequently, depending on the frequency of use, for a maximum of 4 cleaning cycles, then it must be replaced.

STORAGE

- If the dehumidifier will not be used for a long period of time, carry out the following checks before storing it: 1. Remove the plug from the socket
 2. Make sure that the water tank is empty and that the continuous condensate drain hose is disconnected.
 3. Clean the appliance with a soft cloth from any dust deposits
 4. Clean the filter

Store the appliance in a cool and dry place away from heat sources.

TROUBLESHOOTING

PROBLEM	POSSIBLE CAUSES	SOLUTION
The dehumidifier does not work. Controls cannot be made.	The temperature is above 32 ° C or below 5 ° C. The internal tank is full. The tank is not positioned correctly. The plug is not connected correctly.	Empty the tank Position the tank correctly. Connect the plug.
Noise suddenly increases during operation	The compressor has just started. Power supply problem. The unit is positioned on an uneven surface.	Place the unit on a regular and stable surface.
Reduced dehumidification effect	Ambient temperature is too low. The filter is full of dust. Doors and windows are open. The entry and exit of the air are blocked. If the unit operates with a temperature between 5 and 15 ° C, the unit will stop for automatic defrosting. The compressor will stop for short periods. After the defrost the unit will resume normal operation. There may be some appliance in the room that emits steam. The room temperature is too low	Clean the filter. Close doors and windows. Remove objects that block the entry and exit of the air. This appliance should operate with a minimum ambient temperature above 5 ° C

On departure, the air may smell musty	Due to the temperature difference of the heat exchanger, the air can have a strange smell on departure.	
The appliance emits noise	The dehumidifier may emit noise if placed on a wooden floor. If the noise seems like a hiss, it is normal, it is the refrigerant that circulates in the appliance.	
There is water in the tank even when the hose for continuous condensate drainage is used	Check the drain connections. The drain hose is not connected properly.	Connect the hose correctly. Remove the drain hose and replace it.
The LED on Power is not lit although the appliance has been connected to the power supply	There is no power or the plug is not inserted correctly.	Check for power. Check that the electrical circuit and plug are not damaged. Check that the cable is not damaged.
The dehumidifier stops working during the dehumidification process.	The room temperature is too high or too low.	The dehumidifier automatically turns on again when the room temperature returns to being suitable for operation.
The humidity in the room does not decrease.	The environment is too large for the capacity of the appliance. The doors and windows of the room are not closed.	
The LED indicating the full water tank (FULL) is on.	The Full LED lights up to remind you that the water tank is full. The tank has been removed or has not been positioned correctly.	Empty the tank Reposition the tank correctly

REGULATION (EU) N. 517/2014 - F-GAS

The unit contains R290, a natural greenhouse gas with global warming potential (GWP) = 3

DRY PURY 11 : Kg. 0,045 = 0,000135 Tonn CO₂ equiv

DRY PURY 13 : Kg. 0,045 = 0,000135 Tonn CO₂ equiv

DRY PURY 17 : Kg. 0,050 = 0,00015 Tonn CO₂ equiv

DRY PURY 21 : Kg. 0,080 = 0,000240 Tonn CO₂ equiv

DRY PURY 25 : Kg. 0,075 = 0,000225 Tonn CO₂ equiv

Do not release R290 into the atmosphere.

INFORMATION FOR THE CORRECT DISPOSAL OF THE PRODUCT IN ACCORDANCE WITH EUROPEAN DIRECTIVE 2012/19/EU



This appliance may not be scrapped with domestic waste at the end of its life cycle. We call your attention to the crucial role played by the consumer in the re-use, recycling and other forms of recovery of such waste.

The appliance must be scrapped by a sorted waste disposal centre or by returning it to the retailer (no charge is levied for this service), when you purchase a new equivalent appliance.

Sorted disposal of electric and electronic equipment prevents the negative effects on the environment and human health resulting from improper scrapping, and also allows the materials from which it is made to be recovered and recycled, with significant savings in terms of energy and resources.

The sorted disposal requirement is indicated by the crossed waste bin label affixed to the appliance.

Specialist's Manual

Aptitude requirement for maintenance man (repairs should be done only by specialists).

a) Any person who is involved with working on or breaking into a refrigerant circuit should hold a current valid certificate from an industry-accredited assessment authority, which authorises their competence to handle refrigerants safely in accordance with an industry recognised assessment specification.

b) Servicing shall only be performed as recommended by the equipment manufacturer. Maintenance and repair requiring the assistance of other skilled personnel shall be carried out under the supervision of the person competent in the use of flammable refrigerants.

Safety preparation work

The maximum refrigerant charge amount is shown on the following table a

(Note: Please refer to the nameplate for the charging quantity of R290)

Room area (m ²)	4	11	15
Maximum charge (kg)	<0.152	0.225	0.304

table a - Maximum charge (kg)

Prior to beginning work on systems containing flammable refrigerants, safety checks are necessary to ensure that the risk of ignition is minimised. For repair to the refrigerating system, the following precautions shall be complied with prior to conducting work on the system.

- Work procedure

Work shall be undertaken under a controlled procedure so as to minimise the risk of a flammable gas or vapour being present while the work is being performed.

- General work area

All maintenance staff and others working in the local area shall be instructed on the nature of work being carried out. Work in confined spaces shall be avoided. The area around the workspace shall be sectioned off. Ensure that the conditions within the area have been made safe by control of flammable material.

- Checking for presence of refrigerant

The area shall be checked with an appropriate refrigerant detector prior to and during work, to ensure the technician is aware of potentially toxic or flammable atmospheres. Ensure that the leak detection equipment being used is suitable for use with all applicable refrigerants, i.e. non-sparking, adequately sealed or intrinsically safe.

- Presence of fire extinguisher

If any hot work is to be conducted on the refrigeration equipment or any associated parts, appropriate fire extinguishing equipment shall be available to hand. Have a dry powder or CO₂ fire extinguisher adjacent to the charging area.

- No ignition sources

No person carrying out work in relation to a refrigeration system which involves exposing any pipe work shall use any sources of ignition in such a manner that it may lead to the risk of fire or explosion. All possible ignition sources, including cigarette smoking, should be kept sufficiently far away from the site of installation, repairing, removing and disposal, during which refrigerant can possibly be released to the surrounding space. Prior to work taking place, the area around the equipment is to be surveyed to make sure that there are no flammable hazards or ignition risks. "No Smoking" signs shall be displayed.

- Ventilated area

Ensure that the area is in the open or that it is adequately ventilated before breaking into the system or conducting any hot work. A degree of ventilation shall continue during the period that the work is carried out. The ventilation should safely disperse any released refrigerant and preferably expel it externally into the atmosphere.

- Checks to the refrigeration equipment

Where electrical components are being changed, they shall be fit for the purpose and to the correct specification. At all times the manufacturer's maintenance and service guidelines shall be followed. If in doubt, consult the manufacturer's technical department for assistance.

The following checks shall be applied to installations using flammable refrigerants:

---The actual refrigerant charge is in accordance with the room size within which the refrigerant containing parts are installed;

---The ventilation machinery and outlets are operating adequately and are not obstructed;

---If an indirect refrigerating circuit is being used, the secondary circuit shall be checked for the presence of refrigerant;

---Marking to the equipment continues to be visible and legible. Markings and signs that are illegible shall be corrected;

---Refrigeration pipe or components are installed in a position where they are unlikely to be exposed to any substance which may corrode refrigerant containing components, unless the components are constructed of materials which are inherently resistant to being corroded or are suitably protected against being so corroded.

- Checks to electrical devices

Repair and maintenance to electrical components shall include initial safety checks and component inspection procedures. If a fault exists that could compromise safety, then no electrical supply shall be connected to the circuit until it is satisfactorily dealt with. If the fault cannot be corrected immediately but it is necessary to continue operation, an adequate temporary solution shall be used. This shall be reported to the owner of the equipment so all parties are advised.

Initial safety checks shall include:

---That capacitors are discharged: this shall be done in a safe manner to avoid possibility of sparking;

---That no live electrical components and wiring are exposed while charging, recovering or purging the system;

---That there is continuity of earth bonding.

- Repairs to sealed components

During repairs to sealed components, all electrical supplies shall be disconnected from the equipment being worked upon prior to any removal of sealed covers, etc. If it is absolutely necessary to have an electrical supply to equipment during servicing, then a permanently operating form of leak detection shall be located at the most critical point to warn of a potentially hazardous situation.

Particular attention shall be paid to the following to ensure that by working on electrical components, the casing is not altered in such a way that the level of protection is affected. This shall include damage to cables, excessive number of connections, terminals not made to original specification, damage to seals, incorrect fitting of glands, etc.

- Ensure that the apparatus is mounted securely.

- Ensure that seals or sealing materials have not degraded to the point that they no longer serve the purpose of preventing the ingress of flammable atmospheres. Replacement parts shall be in accordance with the manufacturer's specifications.

NOTE: The use of silicon sealant can inhibit the effectiveness of some types of leak detection equipment. Intrinsically safe components do not have to be isolated prior to working on them.

Repair to intrinsically safe components

Do not apply any permanent inductive or capacitance loads to the circuit without ensuring that this will not exceed the permissible voltage and current permitted for the equipment in use.

Intrinsically safe components are the only types that can be worked on while live in the presence of a flammable atmosphere. The test apparatus shall bear the correct rating.

Replace components only with parts specified by the manufacturer. Other parts may result in the ignition of refrigerant in the atmosphere from a leak.

Cabling

Check that cabling will not be subject to wear, corrosion, excessive pressure, vibration, sharp edges or any other adverse environmental effects. The check shall also take into account the effects of aging or continual vibration from sources such as compressors or fans.

Detection of flammable refrigerants

Under no circumstances shall potential sources of ignition be used in the searching for or detection of refrigerant leaks. A halide torch (or any other detector using a naked flame) shall not be used.

Leak detection methods

The following leak detection methods are deemed acceptable for all refrigerant systems.

Electronic leak detectors may be used to detect refrigerant leaks but, in the case of flammable refrigerants, the sensitivity may not be adequate, or may need re-calibration.

(Detection equipment shall be calibrated in a refrigerant-free area.) Ensure that the detector is not a potential source of ignition and is suitable for the refrigerant used.

Leak detection equipment shall be set at a percentage of the LFL of the refrigerant and shall be calibrated to the refrigerant employed, and the appropriate percentage of gas (25 % maximum) is confirmed.

Leak detection fluids are suitable for use with most refrigerants but the use of detergents containing chlorine shall be avoided as the chlorine may react with the refrigerant and corrode the copper pipe-work. If a leak is suspected, all naked flames shall be removed/extinguished.

If a leakage of refrigerant is found which requires brazing, all of the refrigerant shall be recovered from the system, or isolated (by means of shut off valves) in a part of the system remote from the leak. For appliances containing flammable refrigerants, oxygen free nitrogen (OFN) shall then be purged through the system both before and during the brazing process.

Removal and evacuation

When breaking into the refrigerant circuit to make repairs or for any other purpose conventional procedures shall be used. However, for flammable refrigerants it is important that best practice is followed since flammability is a consideration. The following procedure shall be adhered to:

- remove refrigerant;
- purge the circuit with inert gas; evacuate;
- purge again with inert gas;
- open the circuit by cutting or brazing.

The refrigerant charge shall be recovered into the correct recovery cylinders.

For appliances containing flammable refrigerants, the system shall be flushed with OFN to render the unit safe. This process may need to be repeated several times. Compressed air or oxygen shall not be used for purging refrigerant systems.

For appliances containing flammable refrigerants, flushing shall be achieved by breaking the vacuum in the system with OFN and continuing to fill until the working pressure is achieved, then venting to atmosphere, and finally pulling down to a vacuum. This process shall be repeated until no refrigerant is within the system. When the final OFN charge is used, the system shall be vented down to atmospheric pressure to enable work to take place. This operation is absolutely vital if brazing operations on the pipe-work are to take place.

Ensure that the outlet for the vacuum pump is not close to any ignition sources and that ventilation is available.

Charging procedures

In addition to conventional charging procedures, the following requirements shall be followed.

- Ensure that contamination of different refrigerants does not occur when using charging equipment. Hoses or lines shall be as short as possible to minimise the amount of refrigerant contained in them.
- Cylinders shall be kept upright.
- Ensure that the refrigeration system is earthed prior to charging the system with refrigerant.
- Label the system when charging is complete (if not already).
- Extreme care shall be taken not to overfill the refrigeration system.

Prior to recharging the system, it shall be pressure-tested with the appropriate purging gas.

The system shall be leak-tested on completion of charging but prior to commissioning. A follow up leak test shall be carried out prior to leaving the site.

Decommissioning

Before carrying out this procedure, it is essential that the technician is completely familiar with the equipment and all its detail. It is recommended good practice that all refrigerants are recovered safely. Prior to the task being carried out, an oil and refrigerant sample shall be taken in case analysis is required prior to re-use of reclaimed refrigerant. It is essential that electrical power is available before the task is commenced.

- a. Become familiar with the equipment and its operation.
- b. Isolate system electrically.
- c. Before attempting the procedure, ensure that:
 - mechanical handling equipment is available, if required, for handling refrigerant cylinders;
 - all personal protective equipment is available and being used correctly;
 - the recovery process is supervised at all times by a competent person;
 - recovery equipment and cylinders conform to the appropriate standards.
- d. Pump down refrigerant system, if possible.
- e. If a vacuum is not possible, make a manifold so that refrigerant can be removed from various parts of the system.
- f. Make sure that cylinder is situated on the scales before recovery takes place.
- g. Start the recovery machine and operate in accordance with manufacturer's instructions
- h. Do not overfill cylinders. (No more than 80 % volume liquid charge).
- i. Do not exceed the maximum working pressure of the cylinder, even temporarily.

- j. When the cylinders have been filled correctly and the process completed, make sure that the cylinders and the equipment are removed from site promptly and all isolation valves on the equipment are closed off.
- k. Recovered refrigerant shall not be charged into another refrigeration system unless it has been cleaned and checked.

Labelling

Equipment shall be labelled stating that it has been de-commissioned and emptied of refrigerant. The label shall be dated and signed. For appliances containing flammable refrigerants, ensure that there are labels on the equipment stating the equipment contains flammable refrigerant.

Recovery

When removing refrigerant from a system, either for servicing or decommissioning, it is recommended good practice that all refrigerants are removed safely.

When transferring refrigerant into cylinders, ensure that only appropriate refrigerant recovery cylinders are employed. Ensure that the correct number of cylinders for holding the total system charge are available. All cylinders to be used are designated for the recovered refrigerant and labelled for that refrigerant (i.e. special cylinders for the recovery of refrigerant). Cylinders shall be complete with pressure-relief valve and associated shut-off valves in good working order. Empty recovery cylinders are evacuated and, if possible, cooled before recovery occurs.

The recovery equipment shall be in good working order with a set of instructions concerning the equipment that is at hand and shall be suitable for the recovery of all appropriate refrigerants including, when applicable, flammable refrigerants. In addition, a set of calibrated weighing scales shall be available and in good working order. Hoses shall be complete with leak-free disconnect couplings and in good condition. Before using the recovery machine, check that it is in satisfactory working order, has been properly maintained and that any associated electrical components are sealed to prevent ignition in the event of a refrigerant release. Consult manufacturer if in doubt.

The recovered refrigerant shall be returned to the refrigerant supplier in the correct recovery cylinder, and the relevant waste transfer note arranged. Do not mix refrigerants in recovery units and especially not in cylinders.

If compressors or compressor oils are to be removed, ensure that they have been evacuated to an acceptable level to make certain that flammable refrigerant does not remain within the lubricant. The evacuation process shall be carried out prior to returning the compressor to the suppliers. Only electric heating to the compressor body shall be employed to accelerate this process. When oil is drained from a system, it shall be carried out safely.



improve your life

www.argoclima.com